

Lindab **Facade Cassettes**

Installation instructions

Preparations

Before you start

Lindab Facade Cassettes are an elegant, stylish and maintenance-free facade solution for buildings.

Two different models of the facade cassettes are made: Premium and Classic.

Both types of cassette require a wind- and rainproof base sheet before you begin.

Concave and convex bulges may occur depending on the cassette size, temperature variations, colour choice, covering type and the location and design of the building. Concave and convex bulges are minimised by checking that the base surface is completely even.

The maximum tolerance between an intermediate batten and cassette is 2,5 mm.

Delivery, storage and handling

Lindab Facade Cassettes are delivered to the building site carefully packed on pallets. The pallets must be placed on a level and stable surface and protected from water and dirt. If the cassettes are stored outdoors, ensure that the plastic is not removed until immediately before installation. Handle the cassettes carefully so that the surface is not damaged. Lift the cassettes from the pallet one at a time.

Do not use tools that generate sparks on the cassettes, as this can damage the surface of the cassettes. Brush or wipe off all small metallic residue and other contaminants.

Tools

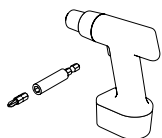

Power driver and bits



Tape measure

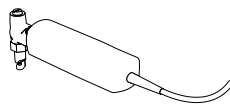

Nibbler



Chalk line

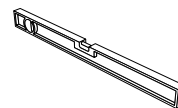

Spirit level

Designing

Depending on how the building is to be designed, facade cassette Premium or façade cassette Classic will suit your building in different ways.

Facade Cassette Premium is an elegant and durable wall covering system. It can be used to cover the whole facade, or just parts of it. The click-design facilitates the installation and minimizes temperature tension between the cassettes. To simplify the installation each cassette-size has its own ID-number marked on the installation drawing as well as on the cassettes. The cassettes are designed with drip angle to prevent corrugation. The bottom surface is also provided with punched holes, to increase the ventilation. When the cassettes are assembled, all fastenings are hidden.

Facade Cassette Classic is a basic way of creating an elegant wall surface. When the cassettes are assembled, the attachments of the screws are visible



Facade Cassette Premium.



Facade Cassette Classic.

Designing

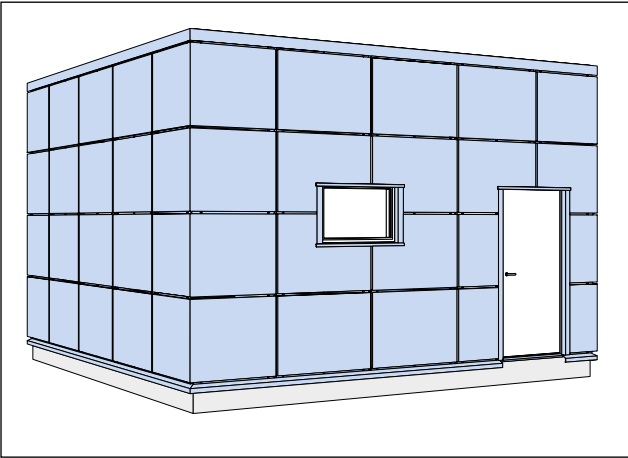

This type of alignment can be made with both Facade Cassette Premium and Facade Cassette Classic.

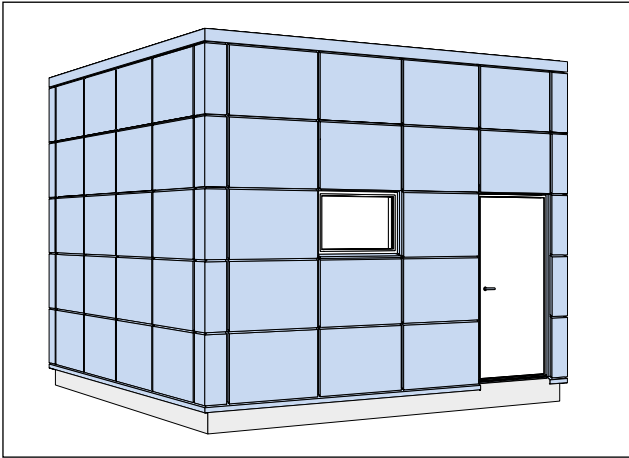

This type of alignment can be made with both Facade Cassette Premium and Facade Cassette Classic.

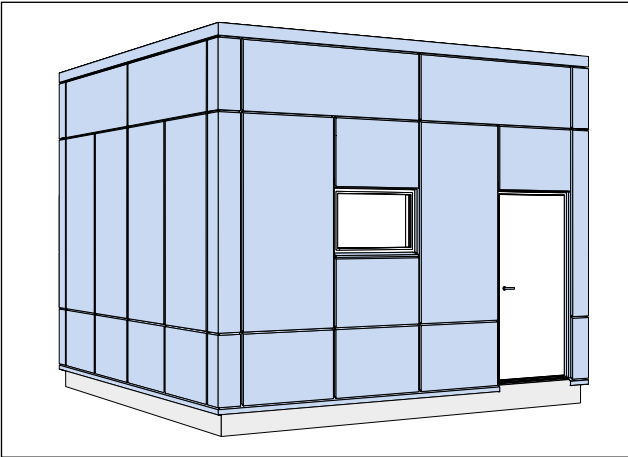

This type of alignment can be made with Facade Cassette Classic.

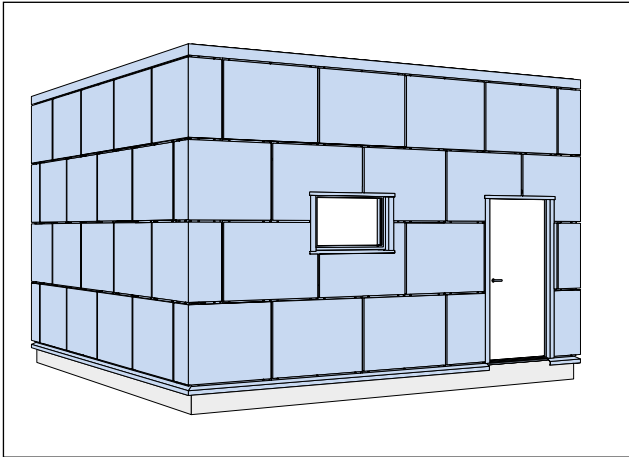

This type of alignment can be made with Facade Cassette Classic.

Designing



Designing

1. Measure the façade on your building

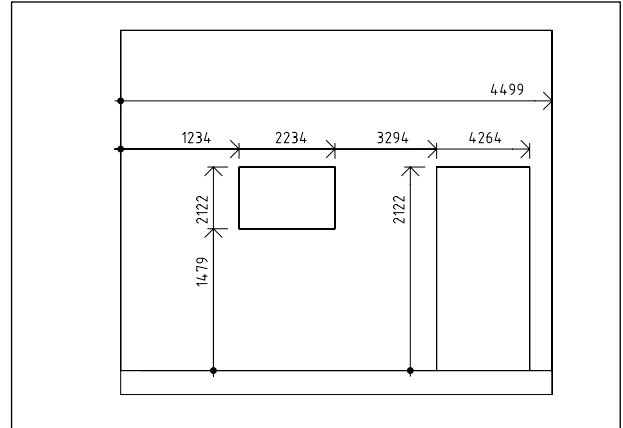
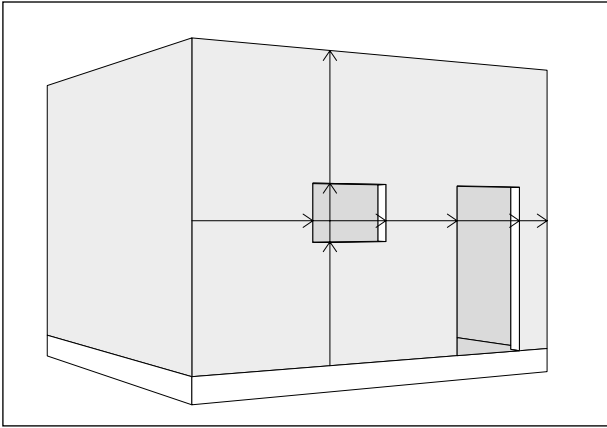

2. Choose where to line the cassettes, or what to align with

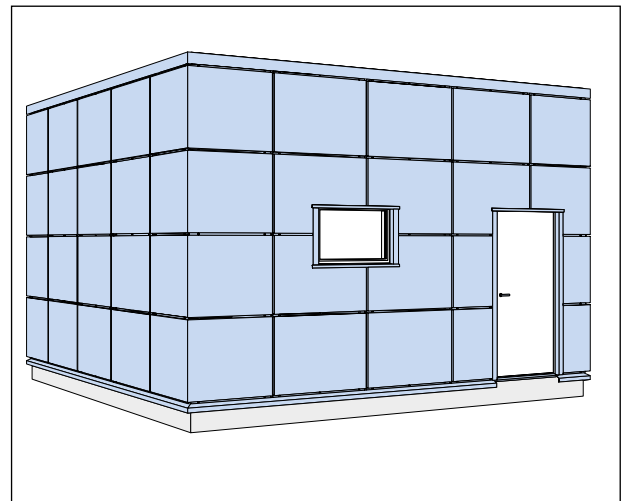
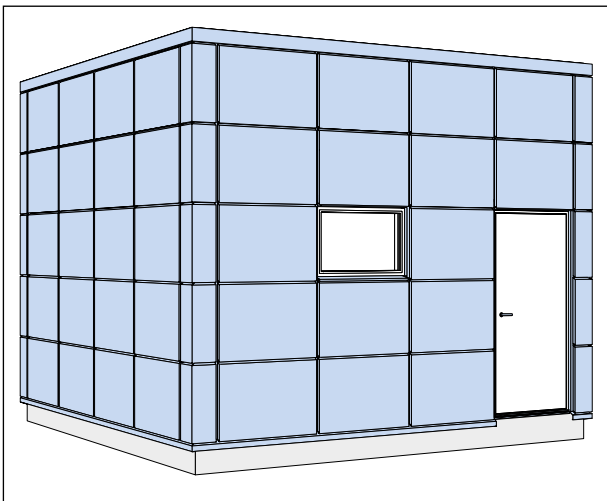

The expression of the building, will be affected of the lines you decide to use as references for the cassettes. We recommend you to choose at least a few lines as a reference.

3. Cassette size

Use the reference line chosen before, and divide the area in to the cassette size you would like to have. In this stage, you also need to consider how to handle windows and doors in the building. Will the cassettes align with them, or do you need to cut the cassette on spot.

If the door and window dont align. Chose wich one that will be the alignment and decide if you will cut the cassette around the other or use a smaler cassette

Technical information

Lindab Facade Cassette Premium

Lindab's Facade Cassette Premium is an extremely flexible system. Cassettes and flashings are manufactured in advance and adapted to the surfaces to be covered. They are delivered with unique ID numbers which indicate where on the wall they should sit. Using the attached drawing, you can see where each cassette or flashing should be mounted. All facade cassettes and flashings are thus delivered so they do not need to be cut to shape. Only

underlying steel battens may need to be cut to fit the height dimensions of the walls.

Mount the facade cassettes to the steel battens using self-drilling screws (mounting screws 5,5x19 mm). The cassettes are designed so that the screws are hidden by overlapping.

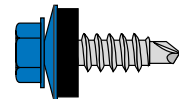

Components

Facade Cassette, FKAS1

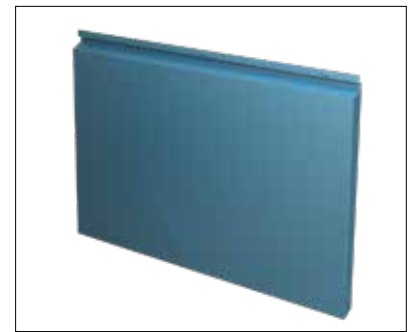
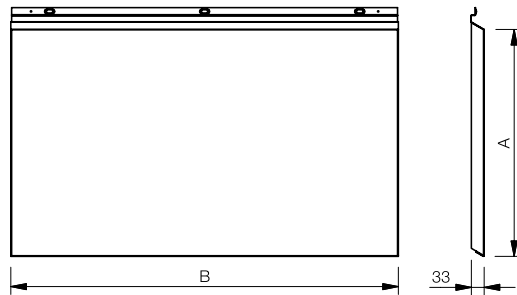

Corner Cassette, FKAS2

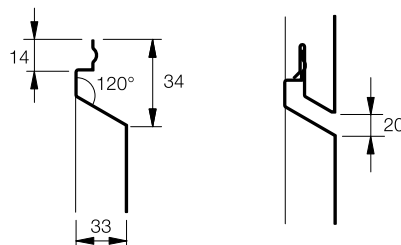
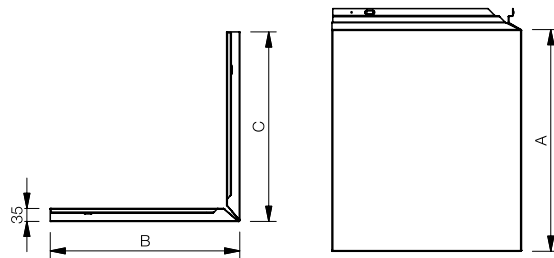

Standard horizontal distance between the cassettes are 30 mm. Recommended distance is between 5 and 50 mm.

Technical information

Lindab Facade Cassette Premium

Components

S7 25 Secondary 0,7 mm

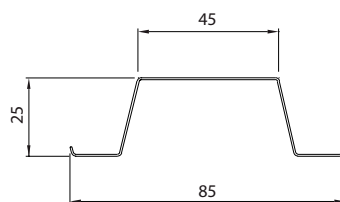

Starter rail, FSTART

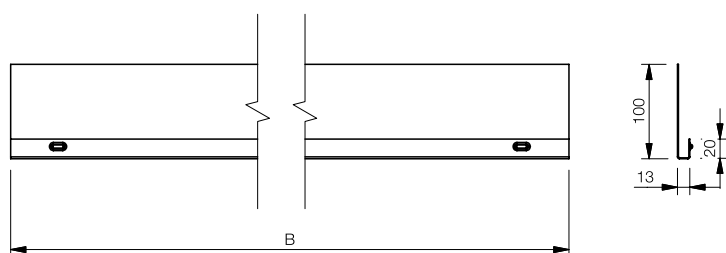

Cover plate, FPPLADE

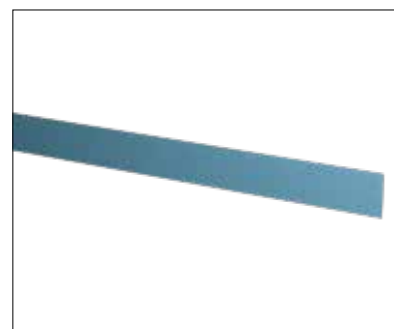
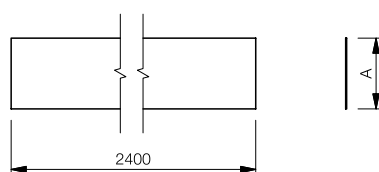

Skirting flashing, FSB

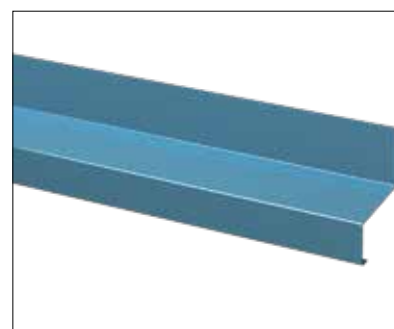
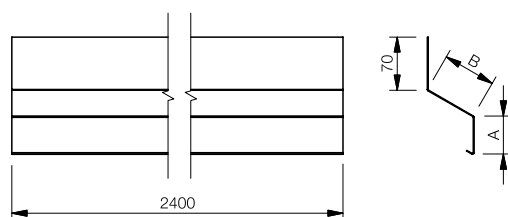

Technical information

Lindab Facade Cassette Premium

Components

Batten profile, FLKT

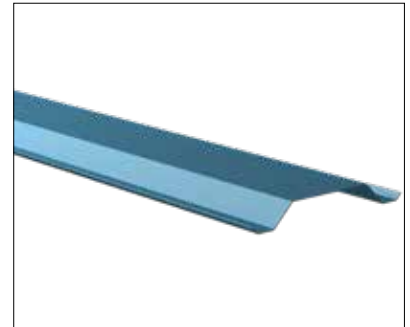
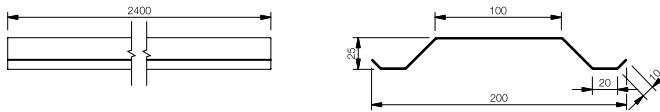

DROP-IT

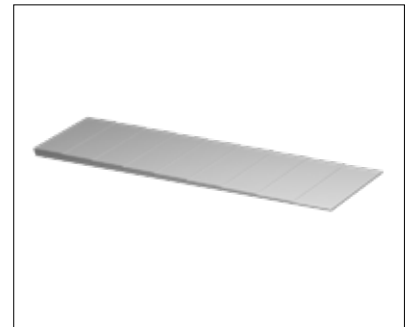
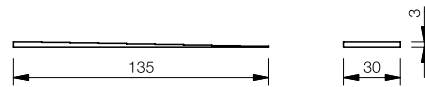

CLIP

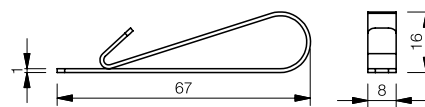

TURN-IT

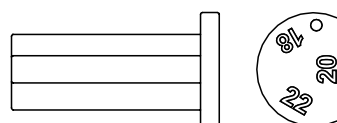

Technical information

Lindab Facade Cassette Classic

Lindab Facade Cassette Classic is ordered according to specific dimensions. Quantity calculations are carried out before ordering and the cassettes are delivered without an accompanying assembly drawing. Planning for batten positioning and adjustments for building openings such as windows and doors are carried out during installation.

Batten positioning

Lindab Facade Cassette Classic is mounted on Lindab S7 25 steel battens. If the cassette is wider than 700 mm, an intermediate batten between the outer battens is also required. See the table below for the number of intermediate battens for different cassette widths.

Fix the facade cassettes to the steel battens using self-drilling screws (mounting screws 5,5x19 mm). Remember that the screw heads are visible after assembly, so take care to position them using the same measurement for each cassette, so that they form a straight line visually, both vertically and horizontally.

The preparatory work is of the utmost importance. It is a good idea to check the measurements more than once.

Ensuring that the cassettes are mounted completely flat prevents the end result being a wavy surface.

Remember that the facade cassettes do not create a weatherproof layer on the facade but that the sub-structure must be covered to withstand weather.

Plan how the various fittings for windows and doors must be designed and where they will sit and whether they need to be mounted before or after the facade cassettes.

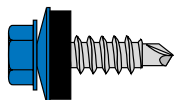

Technical information

Lindab Facade Cassette Classic

Components

Facade Cassette, FKASCL1

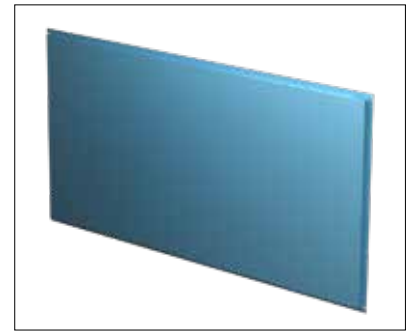
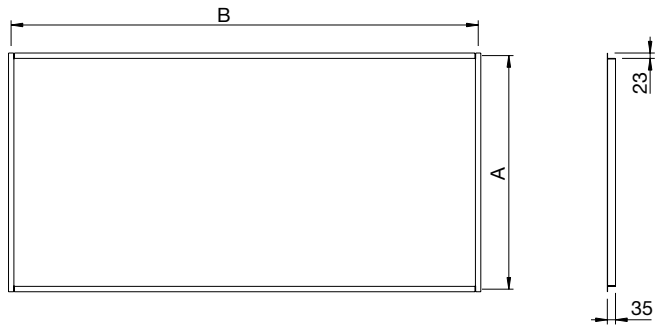

Corner Cassette, FKASCL2

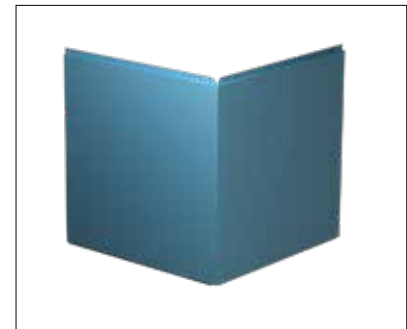
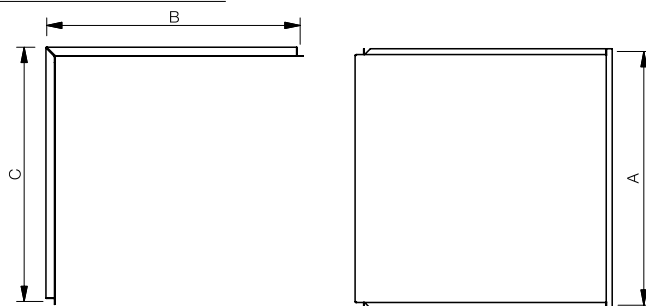

S7 25 Secondary 0,7 mm

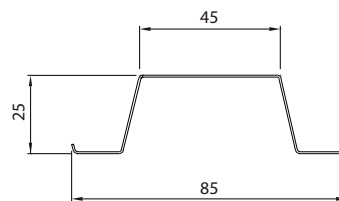

A_M (A_{Mirror})=Mirror width

A_C (A_{Cover})=Covering width

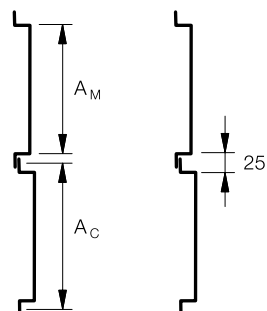

width between cassettes

Battens and the construction behind the cassetts

Lindab Facade Cassette Premium

The cassetts are mounted on battens. We recommend S7 25. Between the cassetts (where there is a visible distance), we recommend a coated batten (FLKT), in the same colour as the cassetts. The facade behind the cassetts has to be water closed, since the cassetts themselves do not create a seald surface.

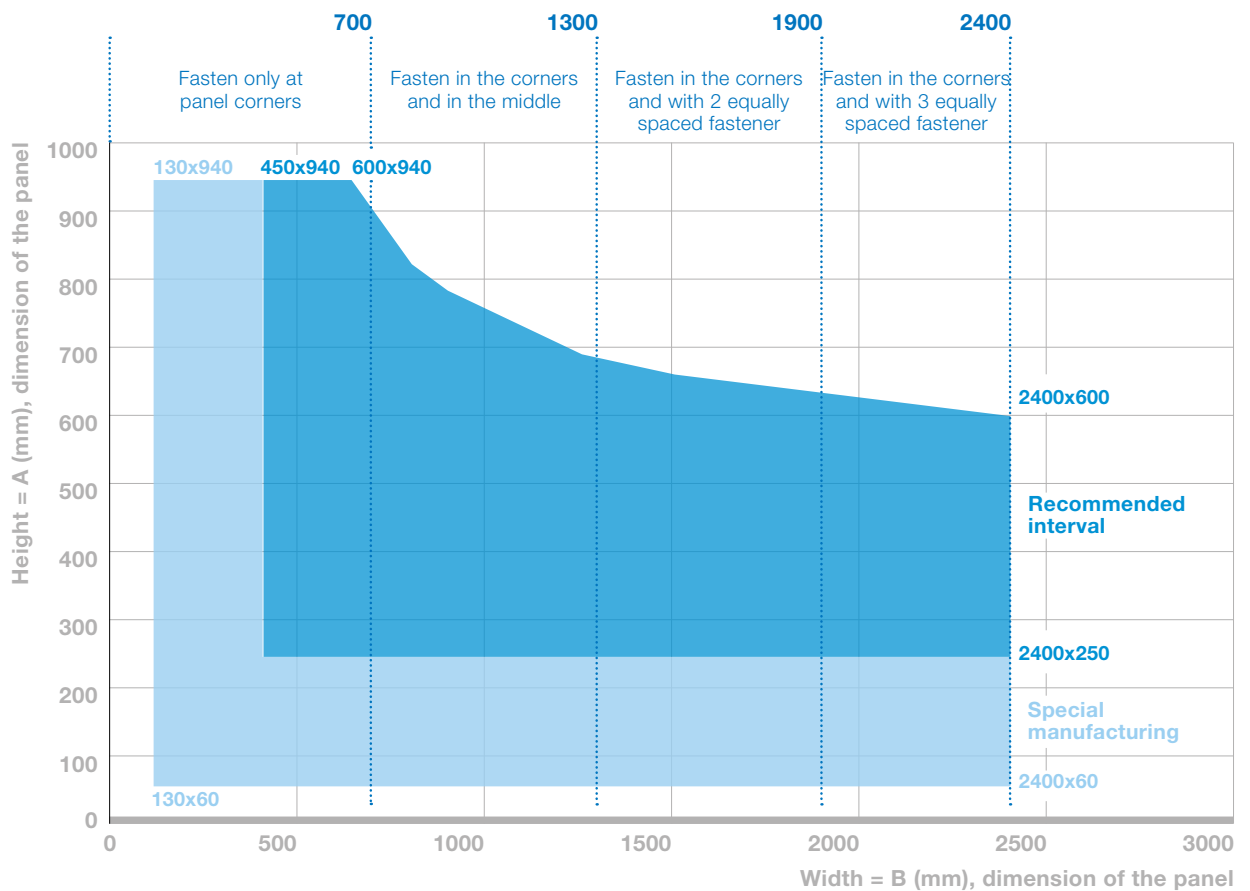
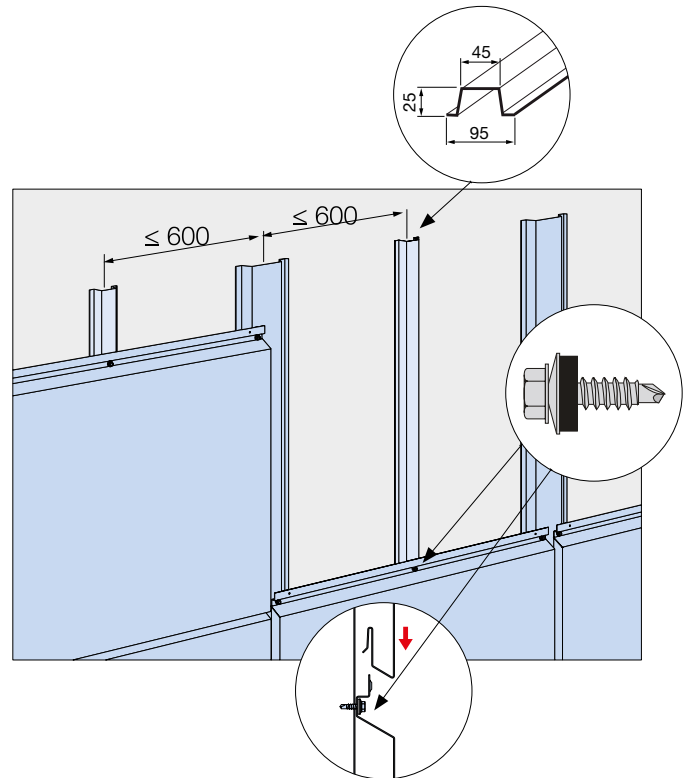

Battens and the construction behind the cassetts

Lindab Facade Cassette Classic

Remember that the facade cassettes do not create a weatherproof layer on the facade but that the sub-structure must be covered to withstand weather.

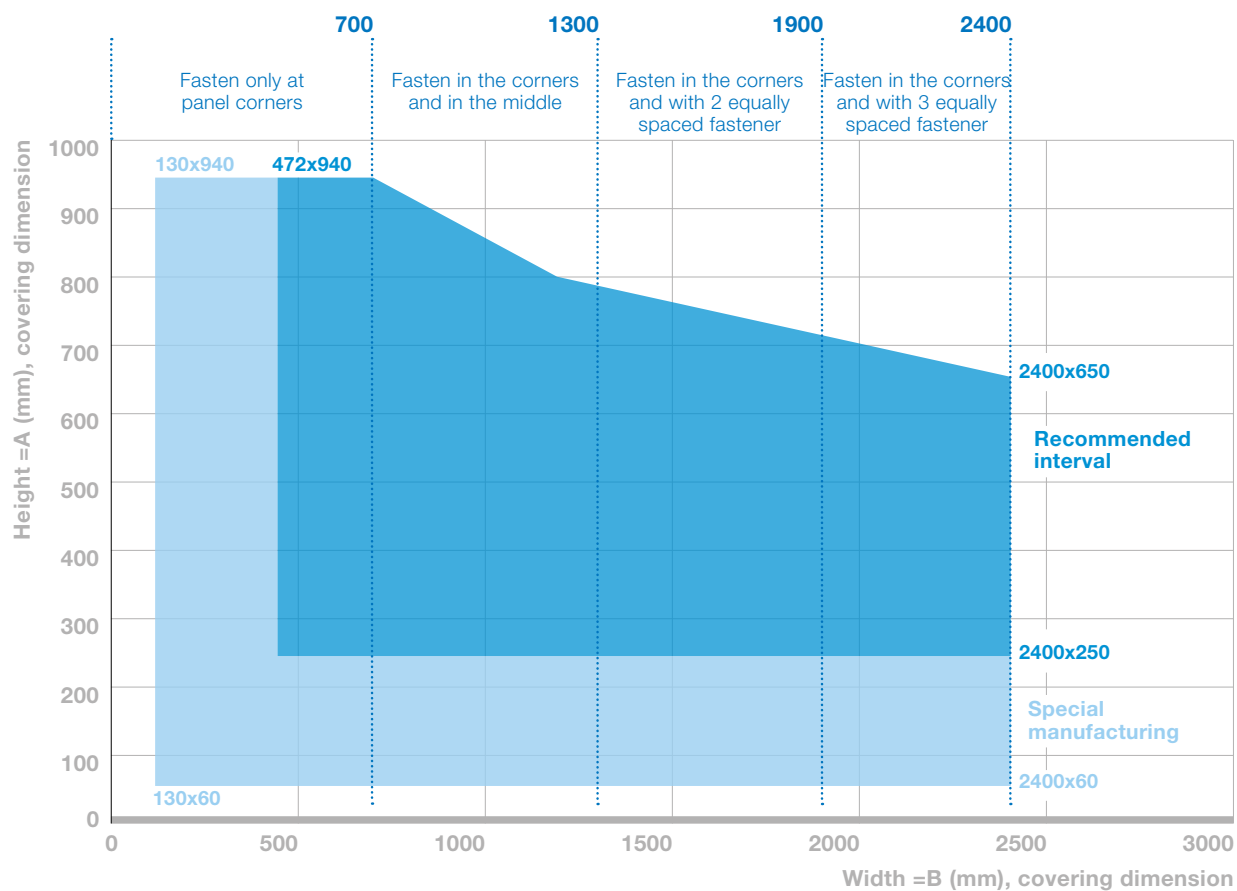
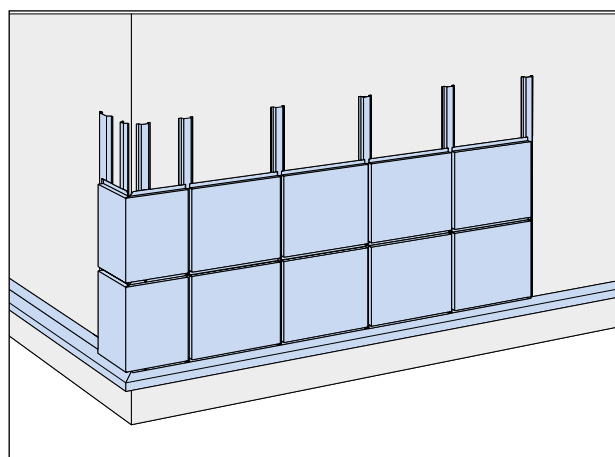
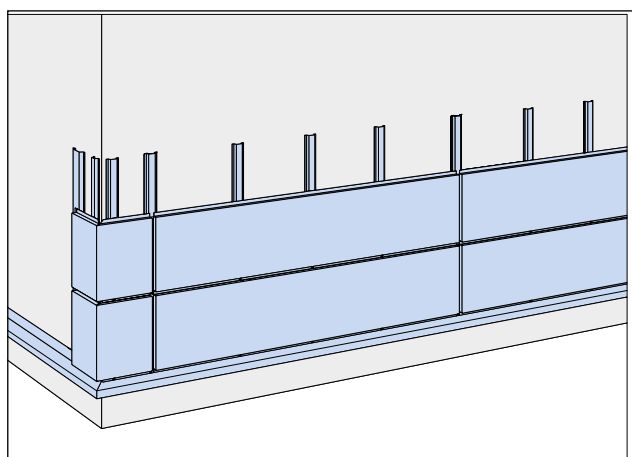

Mounting the cassettes

Lindab Facade Cassette Premium

Mount the facade cassettes to the steel battens using self-drilling screws. The cassettes are designed so that the screws are hidden by overlapping.

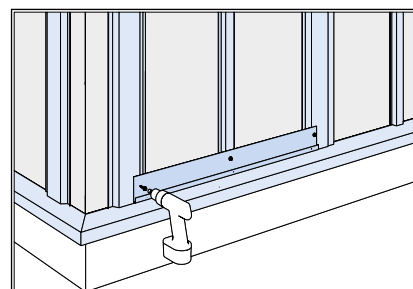
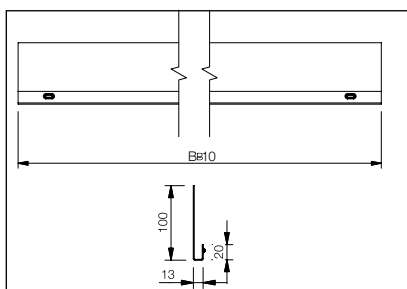
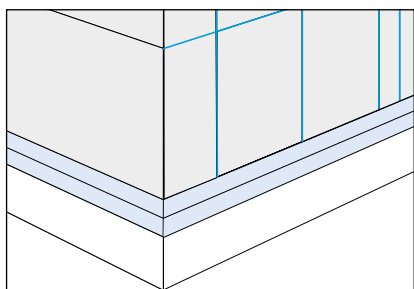

Mount the start-rail. This is 10mm shorter than the B-measure of the cassette.

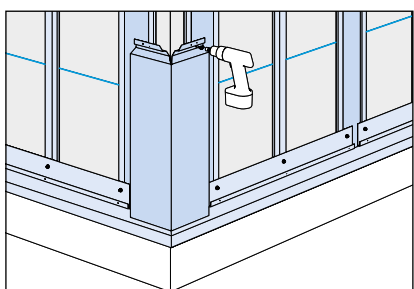

Begin by fixing the corner cassettes according to the measurements taken of the facade.

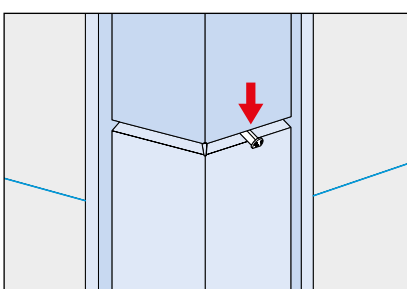

Use the TURN-IT tool to change the distance between the cassettes. The standard measurement is 20 mm.

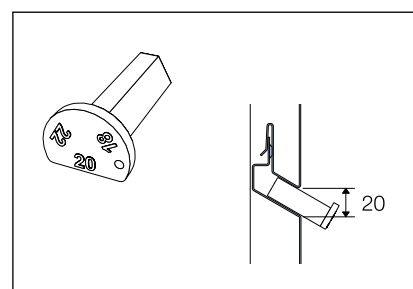

By turning the spacer, the measurements 18 or 22 mm can be used.

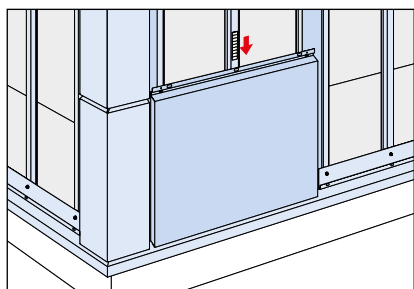

Continue fixing the cassettes to the facade. If there is too much space between the support batten and the cassette, use DROP-IT as a filler.

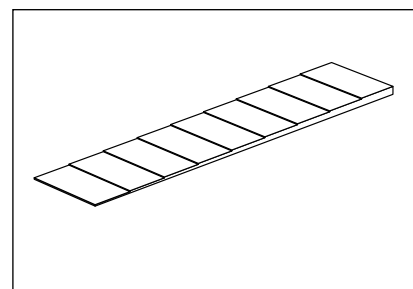
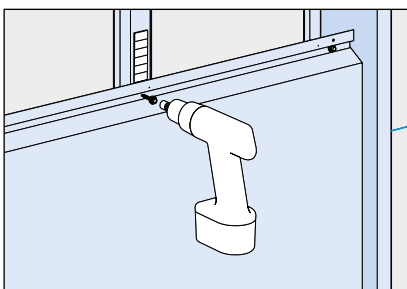

Mounting the cassettes

Lindab Facade Cassette Premium

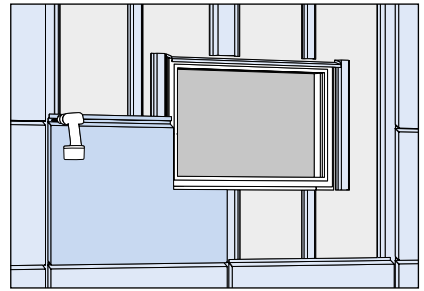
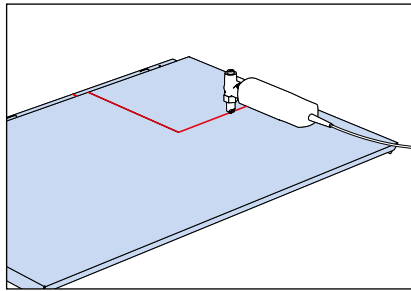
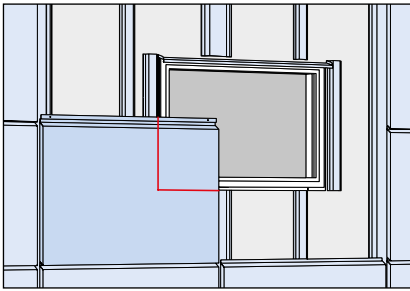

If one would like to give the facade a different type of look, it is possible to adjust the cassettes on the building site and cut out holes and corners for windows and doors.

Mounting the cassettes

Lindab Facade Cassette Classic

Fix the facade cassettes to the steel battens using self-drilling screws (mounting screws 5,5x19 mm). Ensure that the cassettes are mounted completely flat prevents the end result being a wavy surface.

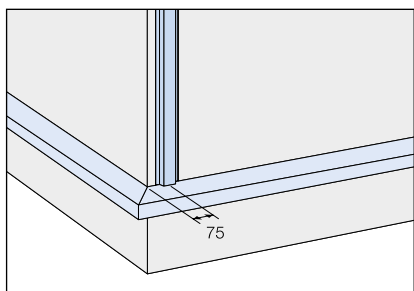

Begin by positioning the battens for the corner cassettes. These are located 75 mm in from the edges of the facade corner edges on each side.

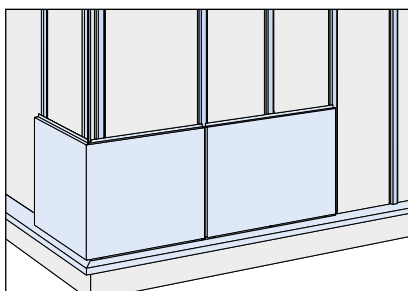

The other battens are positioned according to the table in these assembly instructions.

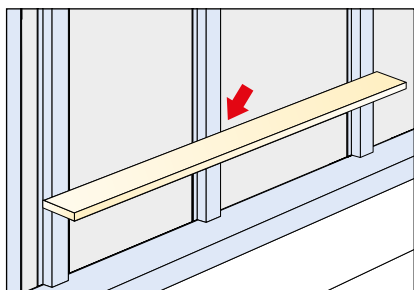

Check the depth of the battens. Use a straight plank.

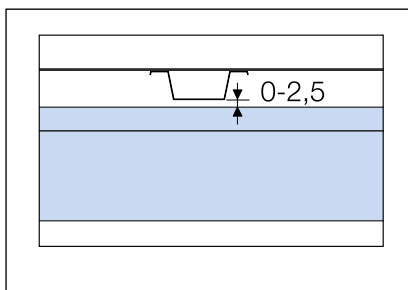

Mounting the cassettes

Lindab Facade Cassette Classic

Cassette assembly

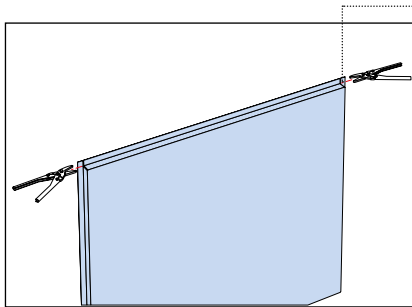

Remember that the two upper outside corners must always be cut away from the cassettes. Otherwise they will build up to a thickness of four plates where the cassettes meet. This is too thick, and will create an uneven surface.

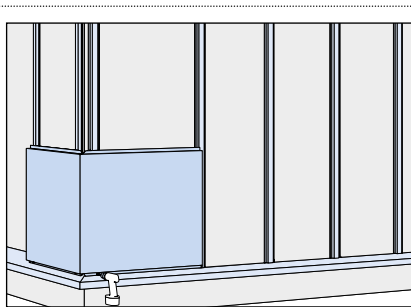

Begin in one corner by fixing the bottom corner cassette. Only fix the bottom edge as the cassette above is screwed into the overlap.

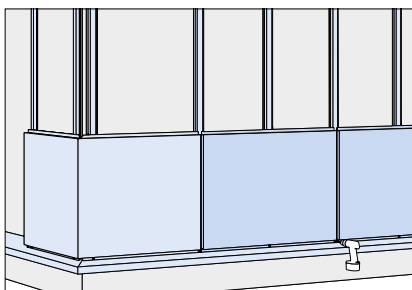
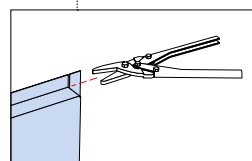

Continue fixing the cassettes for the bottom row.

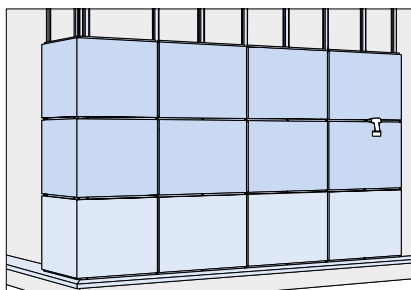

Continue with the second row of cassettes and so on, following the same principle of screwing in the bottom edge where the cassettes overlap.

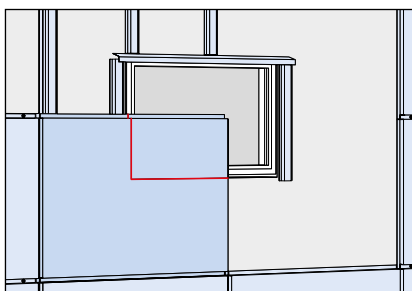

If one would like to give the facade a different type of look, it is possible to adjust the cassettes on the building site and cut out holes and corners for windows and doors.

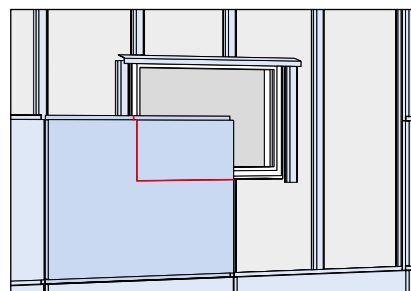
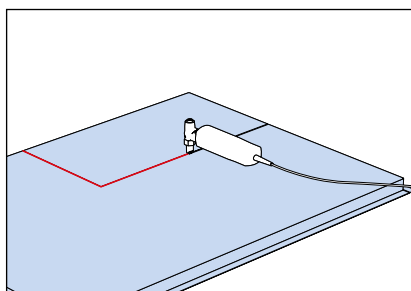

Flashings

Plan how the various fittings for windows and doors must be designed and where they will sit and whether they need to be mounted before or after the facade cassettes.

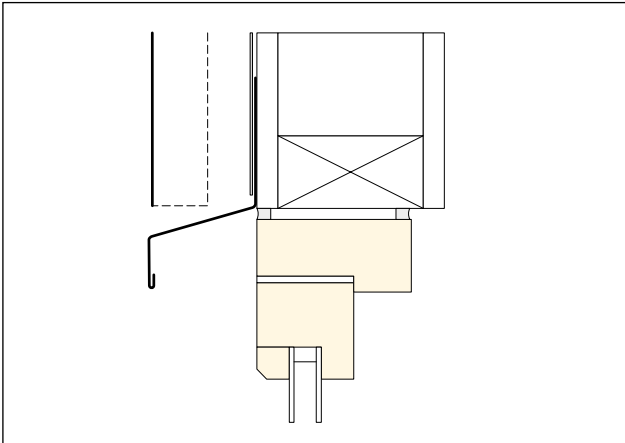

Cross section of a flashing above the window.

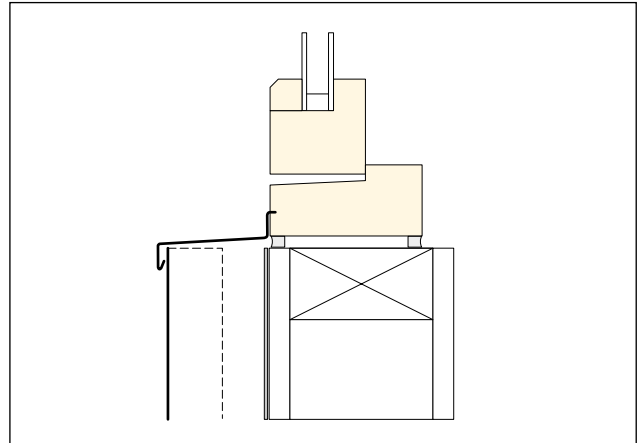

Cross section of a flashing below the window.

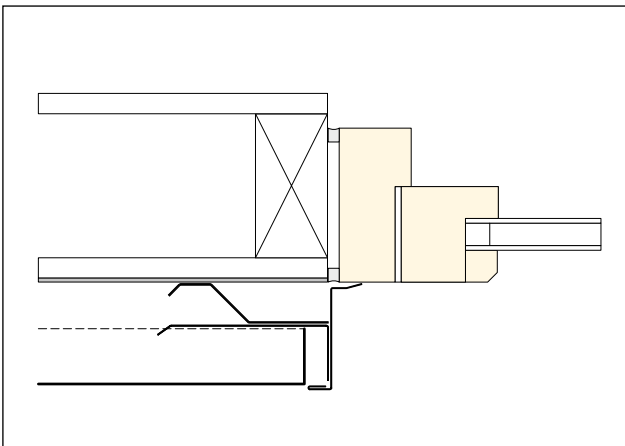

Cross section of a vertical flashing for the window. Seen from above.

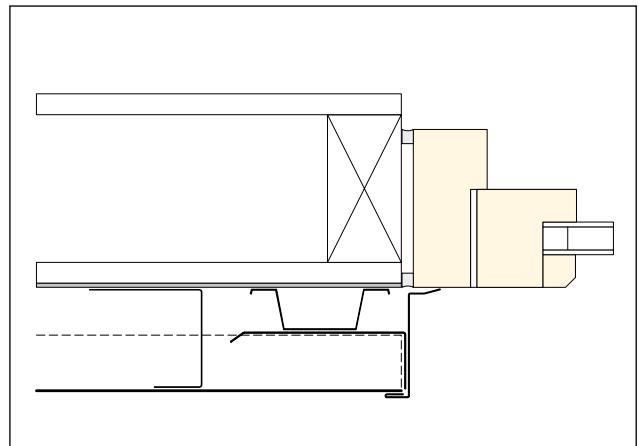

Cross section of a vertical flashing for the window. Seen from above.

Flashings

Batten closure, 1 mm FLKTÄ

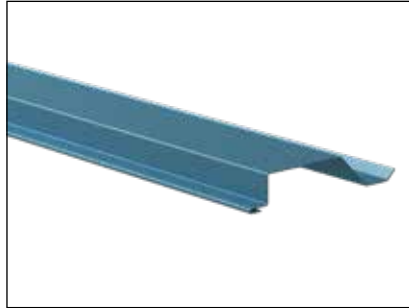
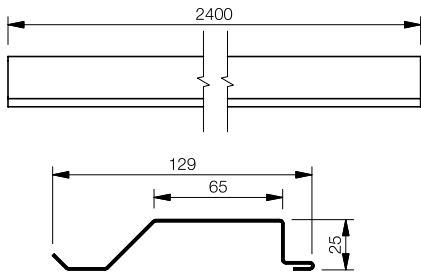

Base flashing, 0,6 mm FSB2

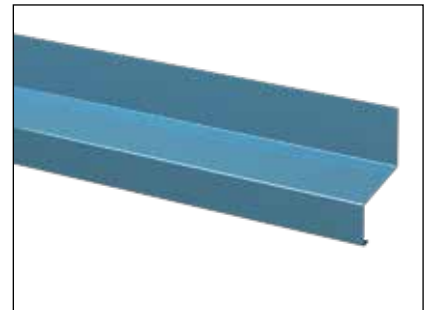
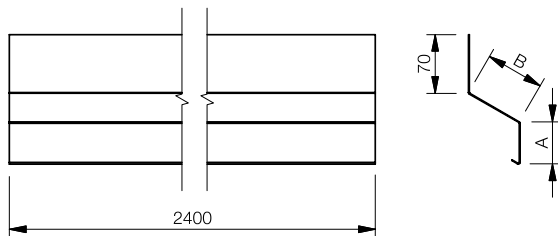

Corner profile FIPU

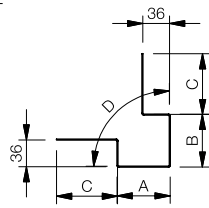
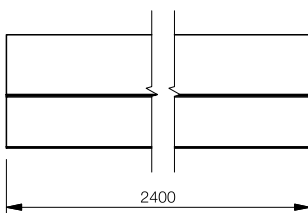

- A 60–200 mm
- B 60–200 mm
- C 0–500 mm
- D 80–100°

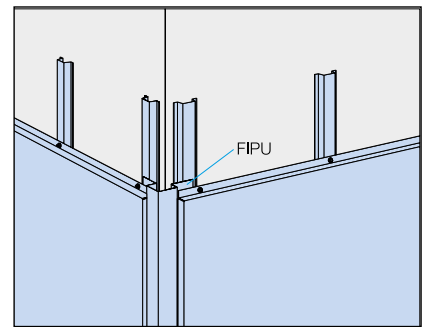
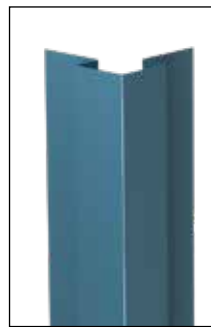

Internal corner profile FIPI

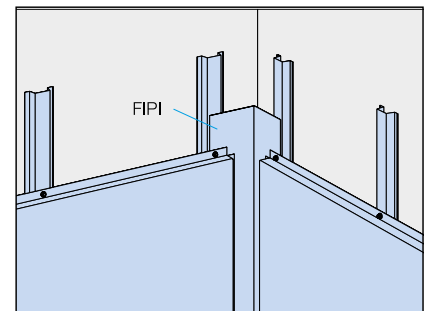
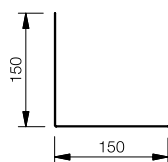
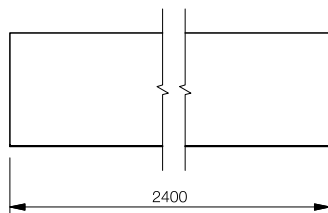



Good Thinking

At Lindab, good thinking is a philosophy that guides us in everything we do. We have made it our mission to create a healthy indoor climate – and to simplify the construction of sustainable buildings. We do that by designing innovative products and solutions that are easy to use, as well as offering efficient availability and logistics. We are also working on ways to reduce our impact on our environment and climate. We do that by developing methods to produce our solutions using a minimum of energy and natural resources, and by reducing negative effects on the environment. We use steel in our products. It's one of few materials that can be recycled an infinite number of times without losing any of its properties. That means less carbon emissions in nature and less energy wasted.

We simplify construction

