

The background features several large, overlapping, wavy lines composed of many thin, parallel lines, creating a sense of motion and depth. These lines curve across the page, framing the central text.

# Mounting

AM 1000

AIRMASTER

## SAFETY INSTRUCTIONS



This manual must be read before installing the Airmaster air handling unit. Following this Manual will ensure this product is operated correctly.

The installation engineer is responsible for ensuring that the unit is installed according to current regulations and standards.

When installing the air handling unit in a room with a fire or stove drawing air from the room, all applicable provisions must be observed.

The unit should not be installed in rooms with abrasive particles or flammable or corrosive gas in the air, in wet rooms or explosion-protected rooms.

The unit should not be used without the filters specified in the Operator's Manual. The manufacturer cannot be held liable for damage arising from use or installing in contravention of these instructions.

The manufacturer reserves the right to make changes without notice. All values stated are nominal values and can be affected by local conditions.

Failure to observe the warnings indicated by a danger symbol implies a risk of personal injury or damage to property.

This manual relates to the Airmaster unit it accompanies plus all equipment, and must be given to and saved by the unit's owner.

All necessary data and guides to network integration can be downloaded from [www.airmaster-as.com](http://www.airmaster-as.com).

## WARNINGS



Service covers may not be opened without first disconnecting the unit's power supply and preventing use.



The unit may not be started up until all service covers and wall grilles on duct connections have been installed.



The fitter must wear personal protective safety equipment, such as safety shoes, during the mouting of the unit.

Place of installation and serial numbers (S/N):

Type: \_\_\_\_\_

Delivery date: \_\_\_\_\_

Place of installation: \_\_\_\_\_

S/N of Air handling unit: \_\_\_\_\_

## Table of Contents

<b>1. General information</b> .....	<b>4</b>
<b>2. Technical specifications</b> .....	<b>5</b>
<b>3. Installation</b> .....	<b>5</b>
3.1. Positioning of the air handling unit.....	5
3.2. Installation of the wall-/ceiling bracket and drilling the duct holes.....	6
3.3. Installation of the air handling unit .....	8
3.3.1. Mounting RC 1000 (option).....	13
3.4. Ducts and wall grilles .....	15
3.5. Roof cap.....	15
3.6. Sealing the gaps around ducts.....	15
3.7. Fitting of panels .....	16
3.8. Mounting check.....	16
<b>Appendix 1 Dimension drawings</b> .....	<b>17</b>
AM 1000 HH TT.....	17
AM 1000 HH BB .....	18
AM 1000 HH DIDE .....	19
AM 1000 HV TB.....	20
AM 1000 VV TT .....	21
AM 1000 VV BB .....	22
AM 1000 VV DE.....	23
AM 1000 S1S2 BB.....	24
AM-RC 1000 HH TT.....	25
Version overview.....	26
Holes to be Drilled for Air Ducts (HV, VV).....	27

# 1. General information

## Scope of delivery:

The Airmaster air handling unit is packed on one pallet. The delivery depends on the customers order.

Please check the delivery before installation. The most important parts are shown below. The scope of delivery can be seen from the delivery note.

- 1. Airmaster air handling unit (4 sections)

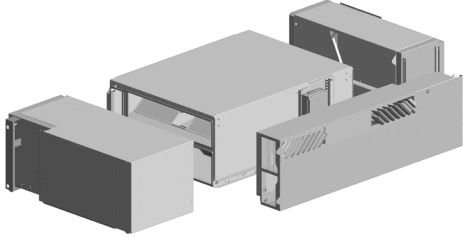

- 2. Wall-/ceiling bracket

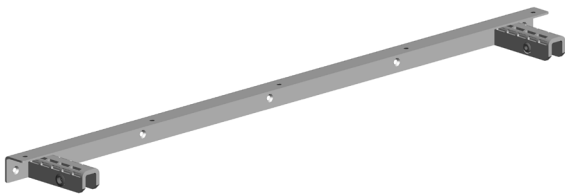

- 3. 4-split service cover

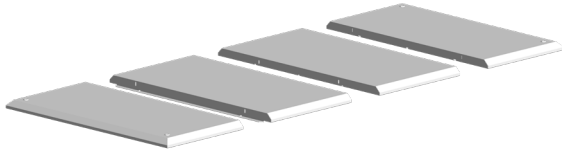

- 4. Panel set (a set consists of one to three long panels and double that number of short panels)



- 5. Control panel

Airlinq Viva



Airlinq Orbit



or

- 6. Roof penetration set (optional)



- 7. Wall grilles (optional)

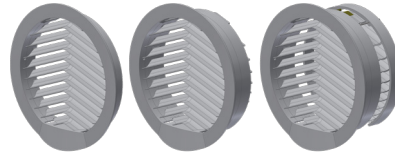

- 8. Room Cooling (RC 1000) (Optional)

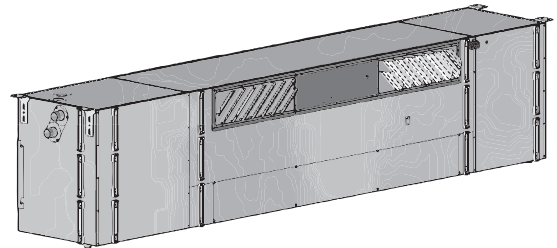

RC 1000 is an option that is intended to be connected to the AM 1000. The RC 1000 is both mechanically and electrically connected to the AM 1000, which means that these two appliances together is considered as one unit. The function of the RC 1000 is to cool down the supply air coming from the AM 1000.

- 9. Operation & Maintenance manual (for programming), Mounting manual, and Installation manual (for installation);

To be handed over to the owner!



## 2. Technical specifications

<b>AM</b>		<b>1000</b>
Weight, Standard unit	kg	301,5
Weight, wall-/ceiling bracket	kg	4,5
Weight, centre module	kg	131
Weight, left module	kg	61
Weight, right module	kg	36
Weight, front module	kg	19
Weight, service cover, set	kg	35
Weight, standard panel (3 set)	kg	15
Weight, standard unit + RC 1000 module	kg	391,5
Colour, Panel	RAL	9010
Colour, Case	RAL	7024
Dimensions	mm	See "Appendix 1 Dimension Drawings"

## 3. Installation



The fitter is responsible for ensuring that the Airmaster air handling unit is properly secured in a horizontal position.



The fitter is responsible for ensuring that any existing functions in the wall/ceiling (e.g. vapour barrier) are restored and fully functional once the unit has been installed.



All screws and other loose parts must be used when mounting the unit.

Read this section fully before starting the installation!

### 3.1. Positioning of the air handling unit

The diagram below shows the most important dimensions relating to the positioning of the unit.

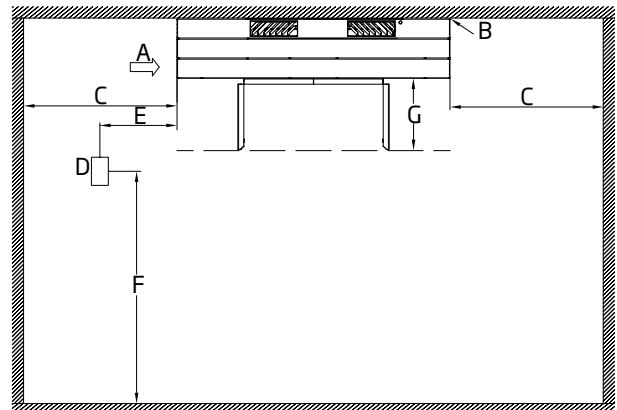

A: Extraction

B: Distance from ceiling: Max. 50 mm

C: Min. distance from wall: 1.5 m

D: CO<sub>2</sub>-sensor (wall mounted)

E: Approximately 1 m

F: Approximately 2 m

G: Free space for maintenance work min. 0.66 m

**A CO<sub>2</sub>-sensor must not be fitted close to a window or door.**

**A smoke detector must not be too close to the supply air flow and extract air flow.**

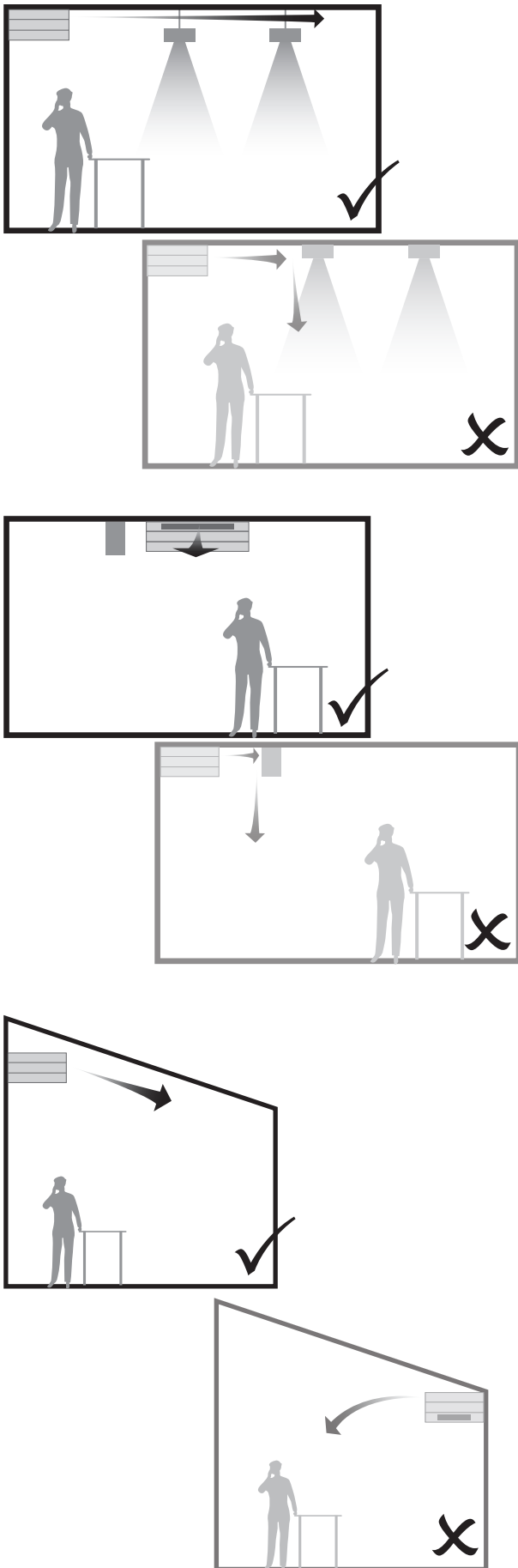

### 3.2. Installation of the wall-/ceiling bracket and drilling the duct holes

**NB!** The air handling unit must be mounted on a solid supporting base by using all possible attachment points. If the wall itself is not sufficiently solid, the air handling unit can be additionally fastened to the ceiling in accordance with 'Appendix 1 Dimension Drawings'.



**NB!** If the air handling unit is not properly affixed, there is a high risk of the air handling unit disengaging from its attachment fittings and falling down. This constitutes a risk of damaging materials and/or causing serious personal injury.



**NB!** The attachment material will depend on the supporting base and the air handling unit and must be suitable for properly supporting the unit's weight of up to 302 kg on the supporting base. When mounting a ventilation unit with a RC 1000 module (optional), the attachment material must be able to properly support a weight of 392 kg.



The wall to which the unit is fitted must have an even surface. If the surface is too uneven, the fitting of the frame may be out of true. This may lead to leaks and an increased noise level during operation of the unit.

It is recommended that the duct holes be drilled 10-15 mm larger than indicated on the drawings as this will allow for subsequent insulation; will prevent direct contact with the wall; and will allow for a vapour barrier etc. to be restored.

A rubber diaphragm for the restoration of a functioning vapour barrier is optionally available and can be delivered by Airmaster.

The duct holes in the wall must have an outward downward gradient of 1-2% to prevent heavy rain from entering the unit.

The holes for the roof ducts must be made oval to be able to install the unit, see 'Appendix 1 Dimension drawings'.

**The unit has to be mounted into a level, horizontal position.**

1. Hold the wall-/ceiling bracket against the wall.
2. Mark all holes, top edge and left edge of wall-/ceiling bracket on wall. Trial fit the wall-/ceiling bracket if necessary.

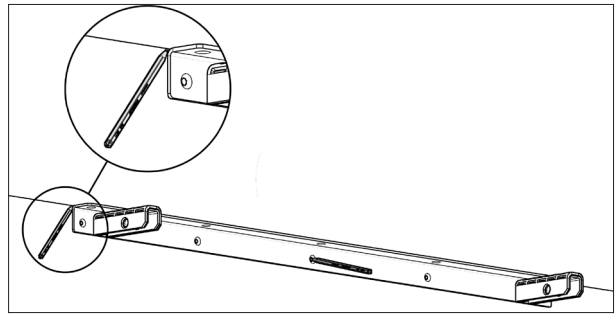

3. Mark the holes for the ducts according to "Appendix 1 Dimension Drawings".

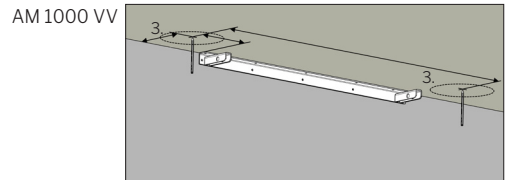
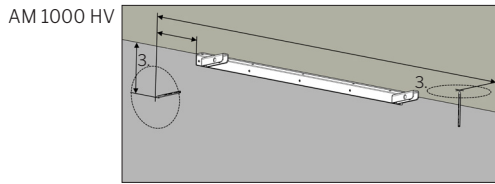
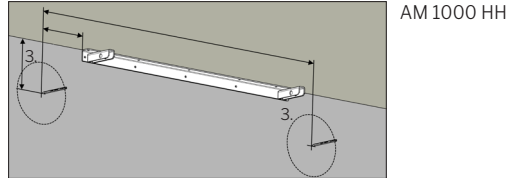

4. Drill all marked holes.

**The hole drilling, size of the holes, and the materials used for fitting depend on the wall-/ceiling material and the unit.**

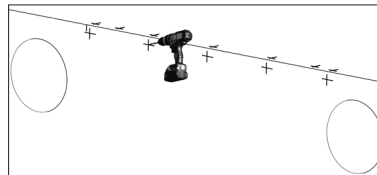

**Wall ducts have to be drilled from both sides of the wall. You have to install a duct reducer from Ø400 to Ø315.**

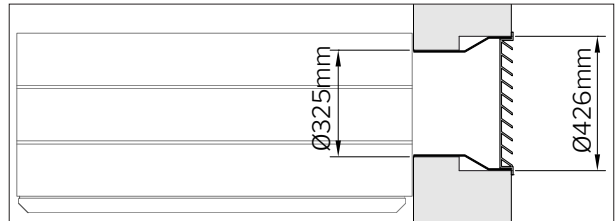

**This does NOT apply to the Airmaster Boomerain® Ø315-1, Ø315-2 and Ø315-3 wall grilles!**

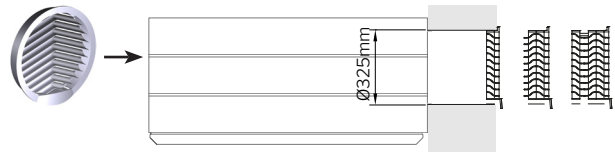

5. Fit the wall-/ceiling bracket. Version 1, 2 or 1+2.

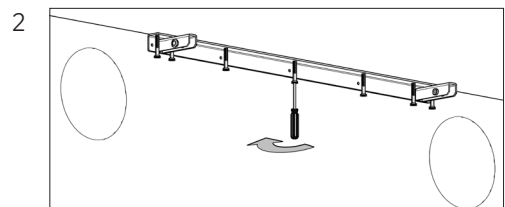
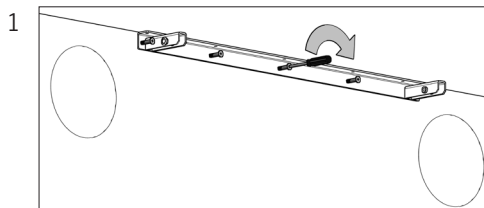

### 3.3. Installation of the air handling unit

The unit has to be mounted into a level, horizontal position.

1. Lift the center section up to the wall bracket, using appropriate lifting equipment.

When lifting the section, a protective underlay must be placed beneath the section to prevent scratches to the section. This underlay may for example be sturdy, clean cardboard or equivalent.

Avoid damaging the profile in the middle of the center section.

2. Push the section against the wall bracket and screw securely to the wall bracket using the bolts provided.

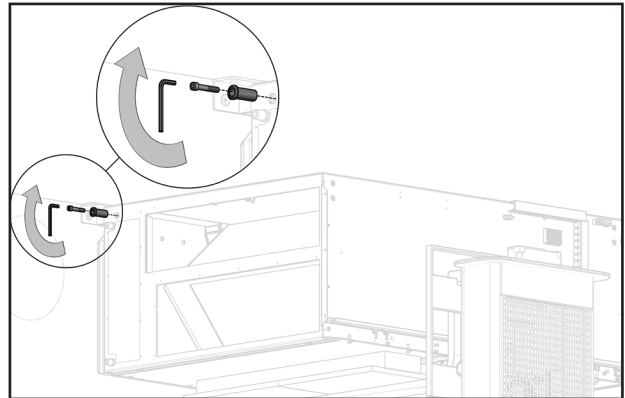
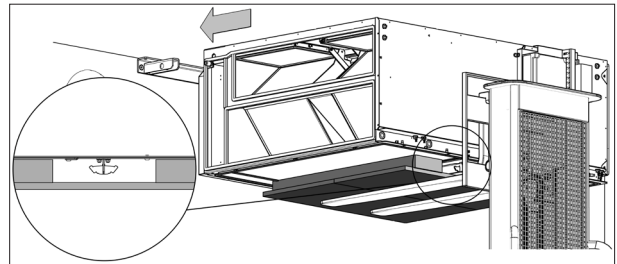

3. Mark and drill the holes for the ceiling brackets.

The hole drilling, size of the holes, and materials used for fitting depend on the ceiling material and the unit.

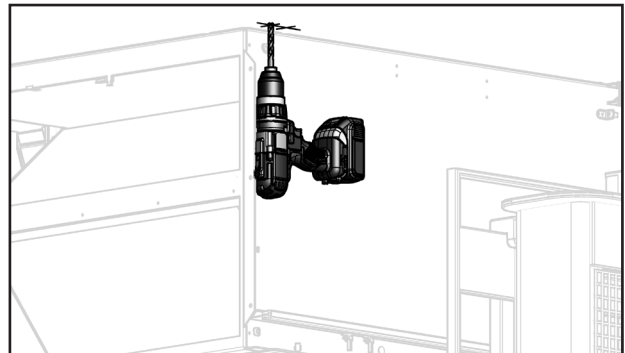
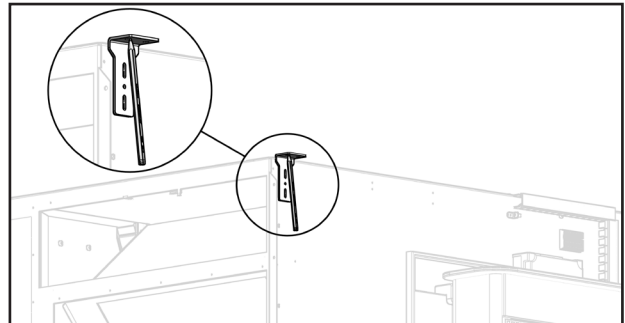

4. Fasten the ceiling brackets to the ceiling.

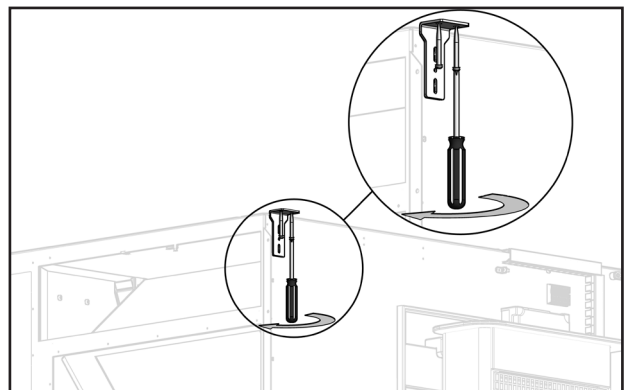

5. Ensure that the section is horizontal.
6. Attach the section to the ceiling brackets, using the provided screws.

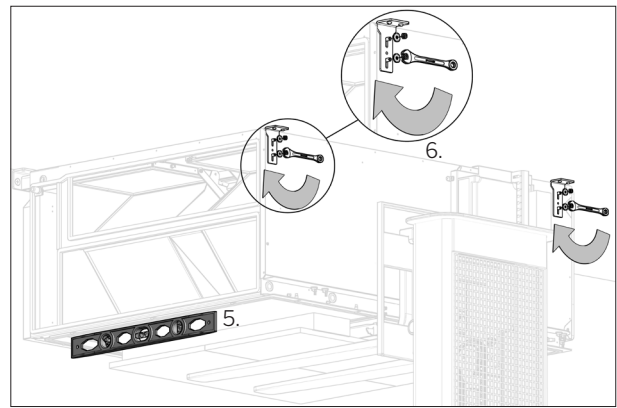

7. Lift the left section using appropriate lifting equipment to the center section.

**When lifting the section, a protective underlay must be placed beneath the section to prevent scratches to the section. This underlay may for example be sturdy, clean cardboard or equivalent.**

8. Push the section onto the bracket on the center section.

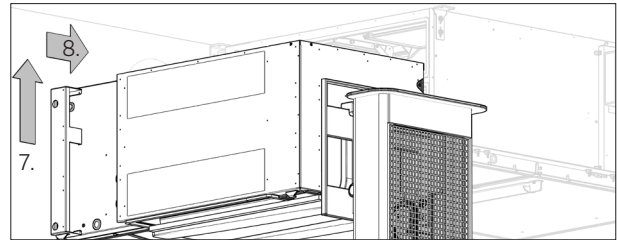

9. Screw the left module to the center module.  
All five screws are already loosely mounted in the modules at the shown positions. The screws must first be unscrewed and then used to fasten the modules together.

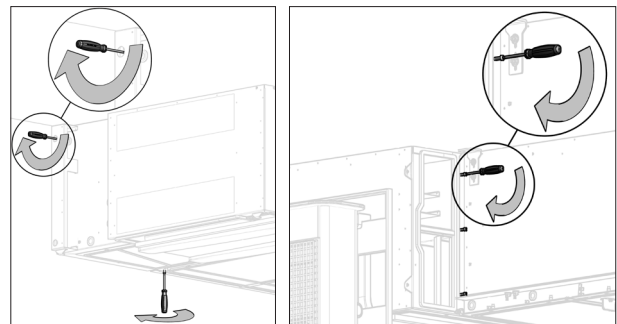

10. Lift the right section to the center section using appropriate lifting equipment.

**When lifting the section, a protective underlay must be placed beneath the section to prevent scratches to the section. This underlay may for example be sturdy, clean cardboard or equivalent.**

11. Push the section onto the bracket on the center section.

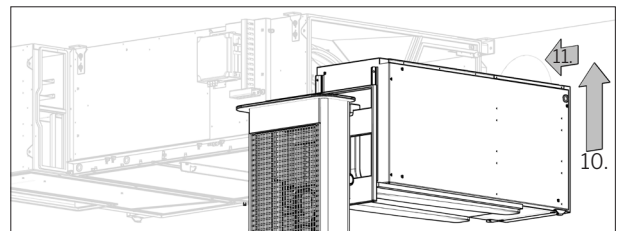

12. Screw the right module to the center module.  
All four screws are already loosely mounted in the modules at the shown positions. The screws must first be unscrewed and then used to fasten the modules together.

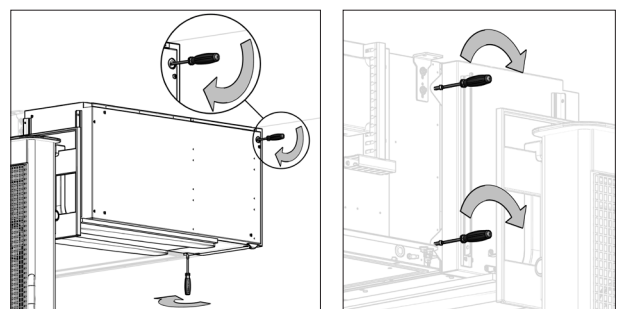

13. Loosen and lower the sliding rails on the section.

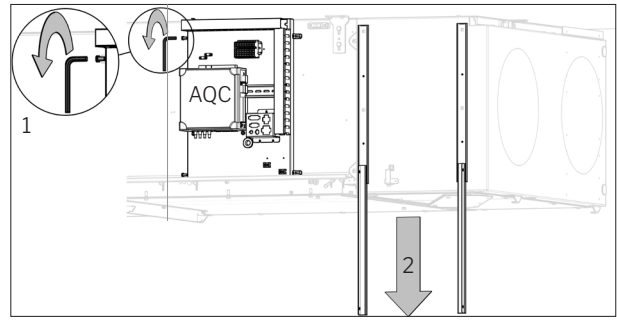

14. Un-screw the base plate containing the control box (AQC) on the center section. Save the four screws for use in next step.

15. Turn the plate 180 °counterclockwise and mount the plate onto the lowered sliding rails on the right section.

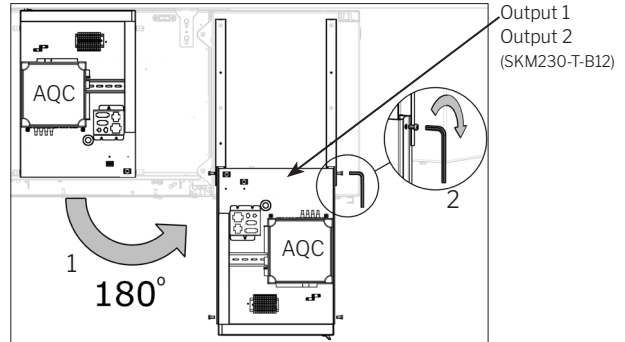

16. Connect the right and left section wires and secure them at the control box (AQC).

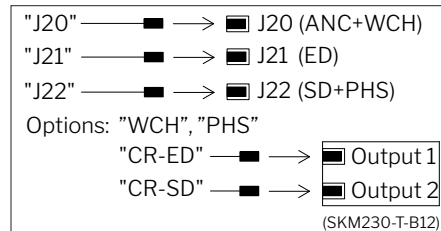

17. Lift the base plate to its uppermost position and secure it.

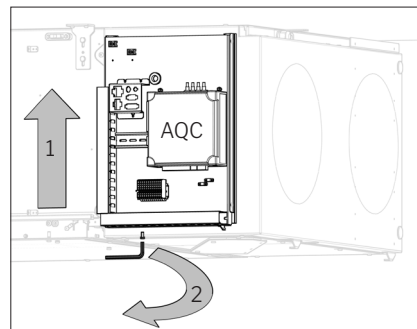

18. Lift the front section to the center section using appropriate lifting equipment.

*When lifting the section, a protective underlay must be placed beneath the section to prevent scratches to the section. This underlay may for example be sturdy, clean cardboard or equivalent.*

**NB: The front module must be lifted up above the wire duct's steel rail to avoid crooked panels later on.**

19. Push the section on the center section.

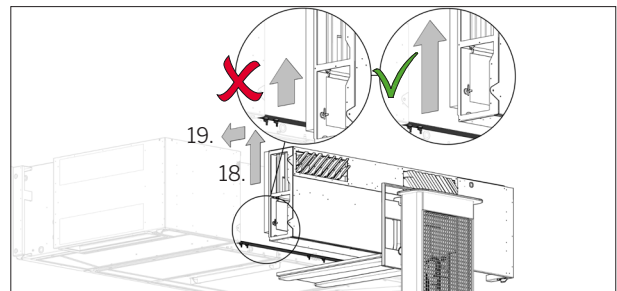

20. Fasten the section to the left and the right sections. Two bolts for the left section and two screws for the right section.

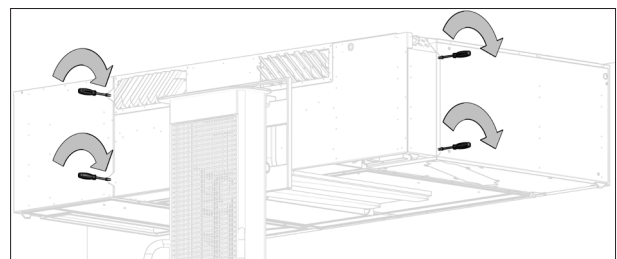

21. Loosen the base plate containing the control box and lower it to its lowest position.

22. Connect the front section wires (J23, PE) and secure them at the control box (AQC).

23. Connect the front section wire (J24) and secure it at the left section.

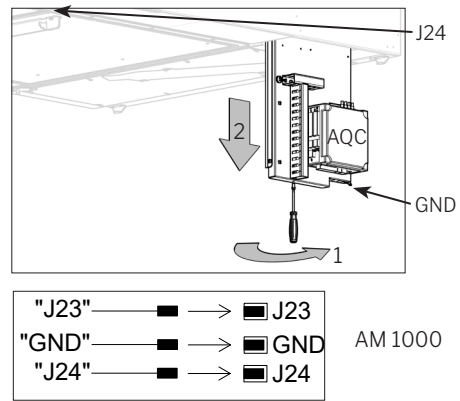

24. AM 1000 with build-in smoke detector only:  
 Connect the front section wires (J2<sub>2</sub>, J2<sub>3</sub>) to the control box (AQC).  
 Connect the front section wires (X1-L1<sub>8</sub>, J20-WCH<sub>BU</sub>) to the terminal block.

AM 1000 with optional build-in smoke detector:

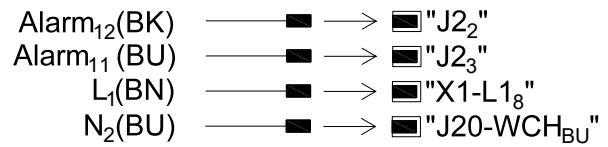

Control box (AQC)

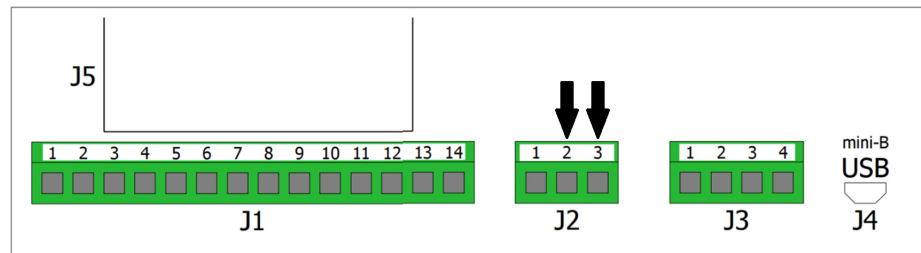

Terminal block

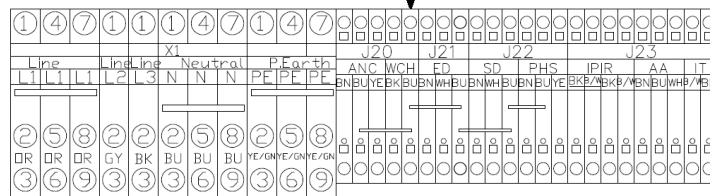

25. Lead the condensate drain hose (1) (option) above the control box (2), through the cable strip (3) to the side of the right section of the air handling unit.

**Do not bend the condensate drain hose!**

26. Lead the condensate drain hose out of the front section at the right top corner.

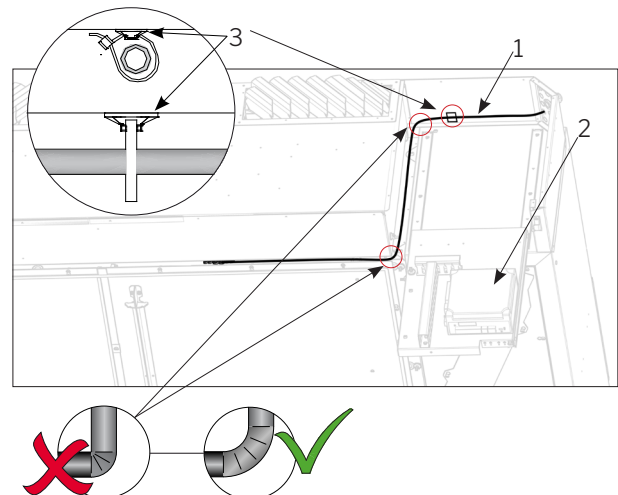

27. Pull the condensate drain hose (1) through the right section of the air handling unit.

**Do not bend the condensate drain hose!**

28. Use the hose connector (4) and the condensate drain hose with 8mm/12mm diameter (5) (internal/external diameter) to pull the condensate drain hose to the waste water system. See the manual "Installation".

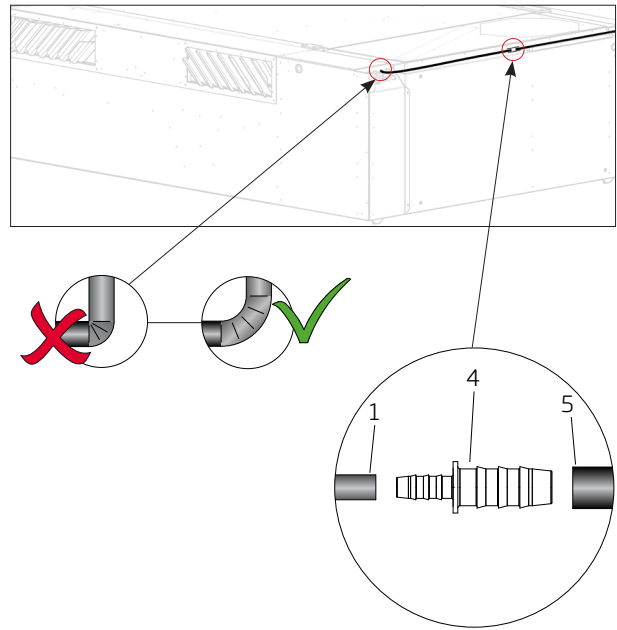

29. Lift the base plate to its uppermost position and secure it.

**\*\* AM 1000 with RC 1000 option. Please go to section 3.3.1 now**

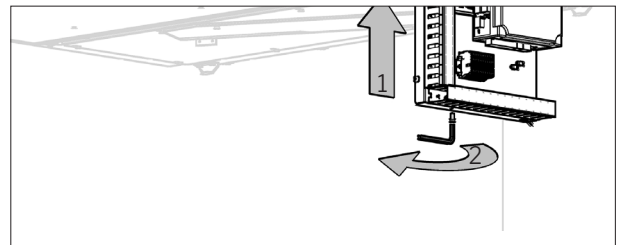

30. Lift the center service covers one at a time using appropriate lifting equipment. Attach the service cover slanted on to the middle rail; push the service cover up against the unit; and fasten it with the three screws provided.

**When lifting the service cover, a protective underlay must be placed beneath the cover to prevent scratches to the section. This underlay may for example be sturdy, clean cardboard or equivalent.**

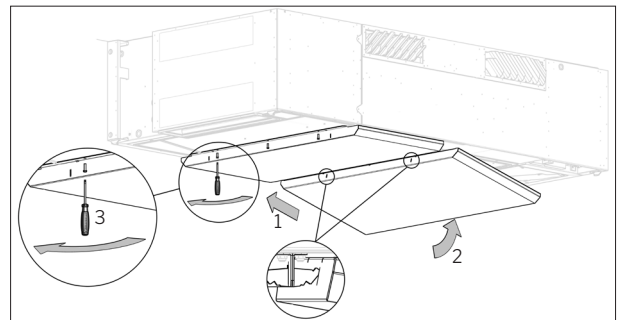

31. Lift the side service covers up next to the center service covers one at a time using appropriate lifting equipment. Hang the service covers slanted onto the center service covers; push them up against the unit; and close them.

**When lifting the service cover, a protective underlay must be placed beneath the cover to prevent scratches to the section. This underlay may for example be sturdy, clean cardboard or equivalent.**

Note the type, delivery date, place of installation and serial numbers (S/N) of the air handling unit on page 2 of both the Mounting manual, the Installation manual, and the Operatoration & Maintenance manual.

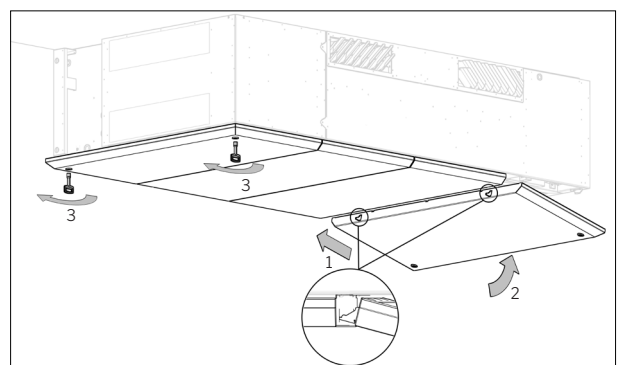

### 3.3.1. Mounting RC 1000 (option)



#### **Intended use:**

The RC 1000 is intended to be installed in a non-industrial setting. Operation of the RC 1000 is intended to be done by layman through the AM 1000's Airmaster Airlinq software. Maintenance, Repairs and De installation of the RC 1000 is only intended to be carried out by instructed personnel.

#### **Unintended use:**

- Blocking of supply air
- Impacting the appliance (footballs, punches etc)
- Excessive switching between outer boundaries (high/low)
- Wrong mounting and installation of the appliance

The weight of the RC 1000 module is supported by the brackets attached on the ceiling.



The brackets connecting the AM 1000 unit and the RC 1000 module are NOT load bearing. RC 1000 must be mounted horizontally and level.

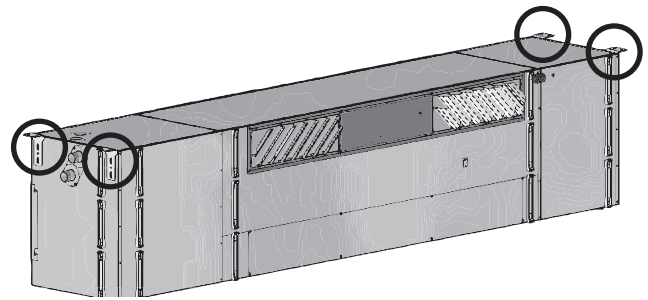

*When lifting the section, a protective underlay must be placed beneath the section to prevent scratches to the section. This underlay may for example be sturdy, clean cardboard or equivalent.*

1. Lift the RC 1000 module using appropriate lifting equipment, to the ceiling where it is to be mounted by the already mounted AM 1000 unit.
2. Attempt a trial mounting of the RC 1000 module on the AM 1000 unit to verify that connecting them is possible.

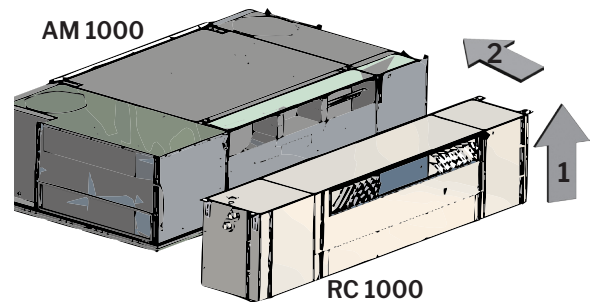

3. Mark all the holes for the ceiling brackets.
4. If necessary drill all the necessary holes

*The hole drilling, size of the holes, and the materials used for fitting depend on the wall-/ceiling material and the unit.*

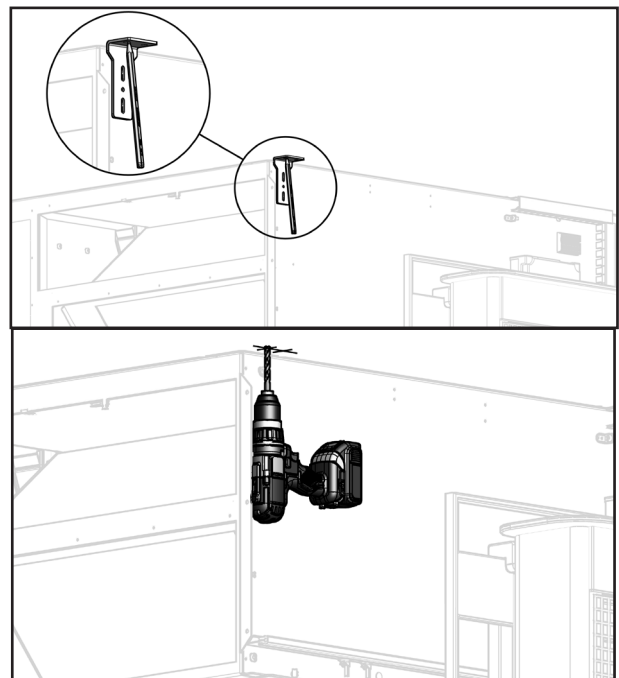

5. Fasten the ceiling brackets to the ceiling.
6. Fasten the RC 1000 module securely to the ceiling brackets using the provided screws.
7. Connect the brackets on the AM 1000 unit to the screws on the RC 1000 module.

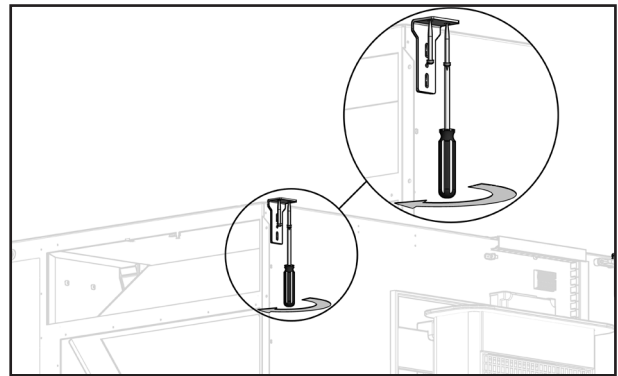

8. Loosen the base plate containing the control box (AQC) and lower it.

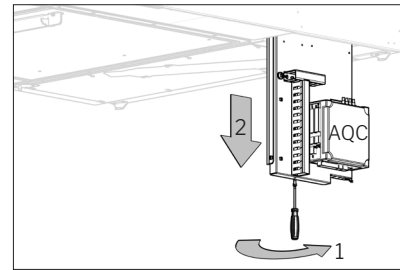

9. Connect the RC 1000 module's wires (J23, PE, J25) to the control box (AQC) on the AM 1000 unit.

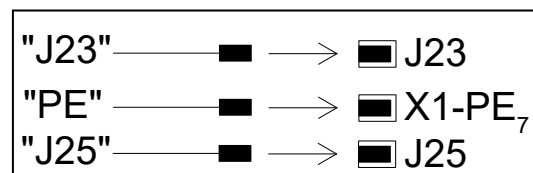

10. Raise the base plate to its uppermost position as before and secure it.

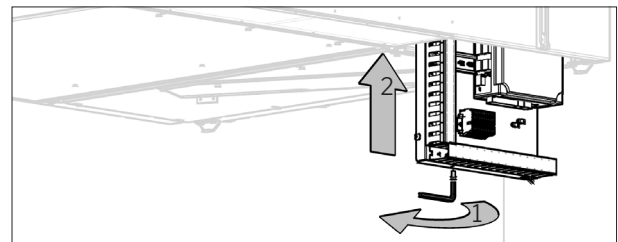

11. The module's condensate drain hose (1) is lead from RC 1000 to the AM 1000 unit (2). The installation of the hose follows the same path through the unit and installation as described in point 24-27 section 3.3 and the installation manual. Notice that each of the condensate drain hoses from the RC 1000 module and AM 1000 unit have their own separate holes at the top of the AM 1000 unit.

12. Service covers and panels are mounted as described in section 3.3. point 29 on page 13 and section 3.7 on page 17.

Notice that there is an extra hole on the RC 1000 module for fastening the service covers. Therefore, the service covers must be fastened in four locations rather than three.

Note the type, delivery date, place of installation and serial numbers (S/N) of the air handling unit on page 2 of both the Mounting manual, the Installation manual, and the Operatoration & Maintenance manual.

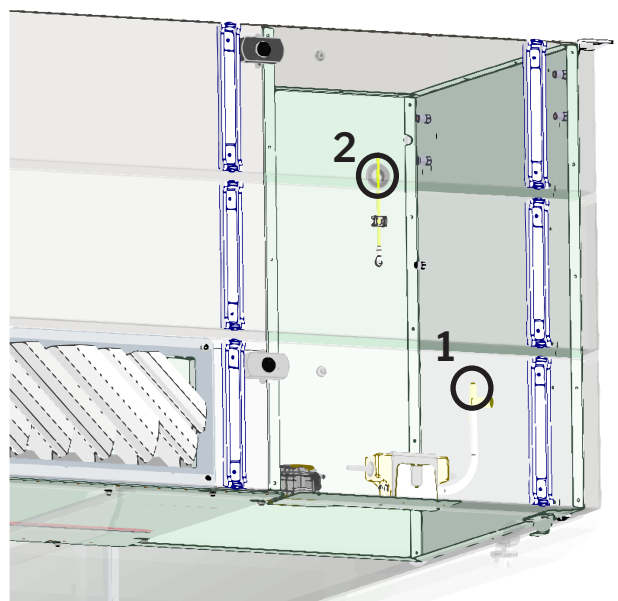

### 3.4. Ducts and wall grilles

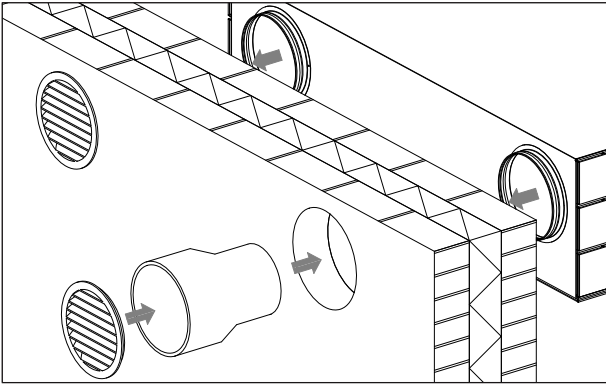

For the AM 1000 (Versions H, S1, S2) you have to use Ø400 wall grilles and reduction pieces Ø400 to Ø315 in the wall. Does not apply to Airmaster Boomerain® Wall Grille Ø315-1, Ø315-2 and Ø315-3.

The materials needed and method of fitting the ducting depend on the unit, the options chosen, and the customer's order.

For this reason, we can provide only general instructions for fitting the ducts.

The length of the ducting is calculated on the basis of the thickness of the wall/dimensions of the roof.

**Please note that the duct holes in the wall must have an outward downward gradient of 1-2% to prevent heavy rain from entering the unit.**

The outdoor air grille for unit versions S1 and S2 should be installed with the slats facing down and the exhaust air grille with vertical slats facing right (Only with Ø400 wall grilles).

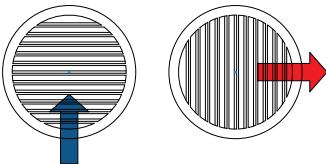

Exhaust air ducts and outdoor air ducts must be insulated against condensation on the ducts, if they are within the building envelope. The extract air ducts and inlet air ducts must be insulated against temperature loss and condensation forming inside the ducts if they are mounted outside the building envelope, or run through an unheated room.

Condensation and heat insulation should be performed according to standards and rules in effect.

**NB! Fire safety regulations must be observed according to standards and rules in effect.**

The installation of ventilation ducts should be performed according to standards and rules in effect.

Exhaust air ducts and outdoor air ducts must be insulated against noise if they are visible.

Finally, fit a suitable circular wall grille with the slats pointing downwards on the outside of the outer wall or a roof cap up on the roof.

To avoid an increase in noise level, it is important that the ducts are not twisted or compressed against the supply air spigot and the outdoor air spigot of the unit.

**Remember to seal around the penetrations. See section '3.6 Sealing the Gaps Around Ducts'.**

### 3.5. Roof cap

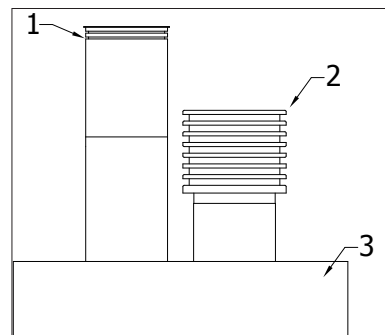

Fit roof caps on the roof to finish off the installation of exhaust and supply through a roof. The installation will depend on the roof construction (3). The illustration shows which roof caps are for exhaust (1) and supply (2).

**Fire safety regulations for the installation of multiple systems must be observed according to the standards and rules in effect.**

### 3.6. Sealing the gaps around ducts

Sealing of the gaps around ducts is performed as shown in the sectional drawing below.

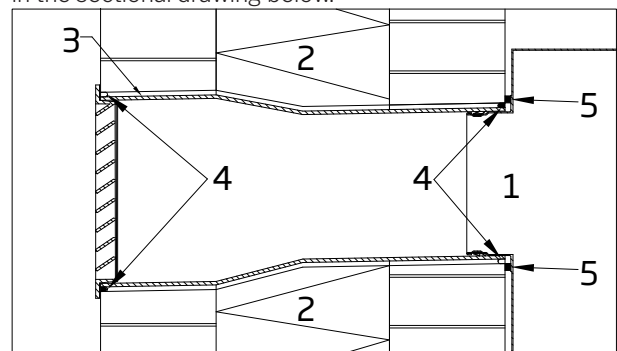

Application of a seal (shown here on a model with wall ducts) is important at the ducts (3) inside and at the outside edges (4) in order to prevent drafts between the unit (1) and the wall/roof (2) as well as between the ducts (3) and the wall/roof (2).

Sealing on the inside between the ducts (3) and the wall/ceiling (2) can also be performed between the air handling unit (1) and the wall/roof (2) at position (5) before fitting the air handling unit.

Depending on the condition of the wall/ceiling and the dimensions of the air handling unit, a sealant that retains elasticity over the long term or expanding sealing tape can be used to obtain a flexible seal. This material is to be applied to the rear of the unit around the air connection fittings, or at the side of the duct holes on the wall to even out irregularities on the wall/ceiling.

### 3.7. Fitting of panels

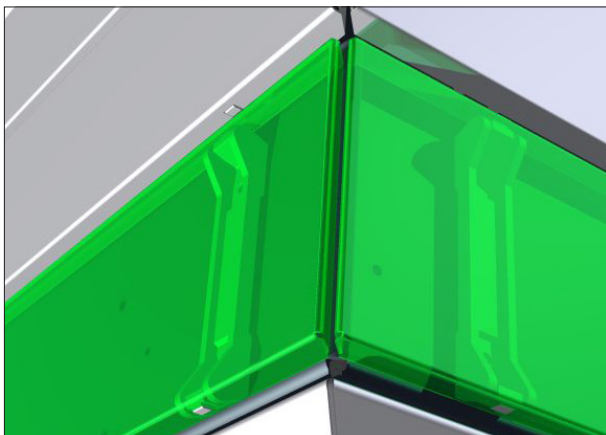
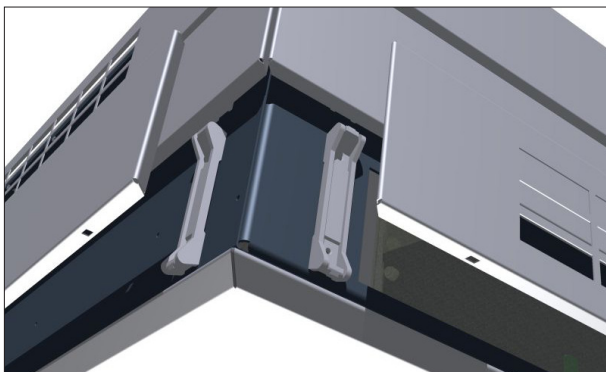

The panels must only be fitted once the unit, complete with all equipment, has been fitted and connected, and the functions of the unit thoroughly tested.

Press the panels to the clips on the unit until they attach securely to the clips.

The perforated circles in the side and rear panels should not be removed until required for ducted connections.

- a: Left panel.
- b: Rear panel.
- c: Right panel.
- D: Perforated section for extraction for DE version.

- E: Perforated section for exhaust for H version.
- F: Perforated section for supply for H version.
- G: Perforated section for supply in S1 version or exhaust in S1 and S2 versions.
- H: Perforated section for supply for S2 version.

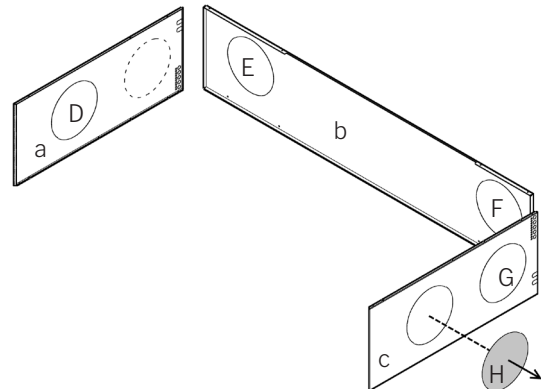

- i: Perforated section for PIR/motion sensor
- J: Front panel.

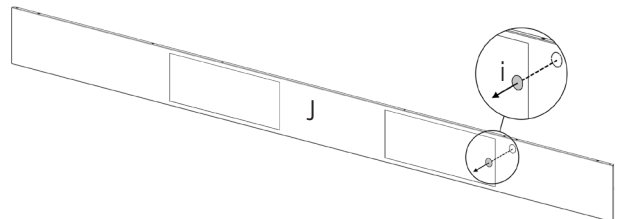

### 3.8. Mounting check

	yes	no
Serial number noted	<input type="checkbox"/>	<input type="checkbox"/>
Wall-/ceiling bracket fitted	<input type="checkbox"/>	<input type="checkbox"/>
Unit fitted	<input type="checkbox"/>	<input type="checkbox"/>
Ceiling brackets attached	<input type="checkbox"/>	<input type="checkbox"/>
Ducts and wall grilles fitted	<input type="checkbox"/>	<input type="checkbox"/>
Roof cap fitted	<input type="checkbox"/>	<input type="checkbox"/>
Screws retightened	<input type="checkbox"/>	<input type="checkbox"/>
Panels fitted	<input type="checkbox"/>	<input type="checkbox"/>

Name of fitter:

Comment:

# Appendix 1 Dimension drawings AM 1000 HH TT

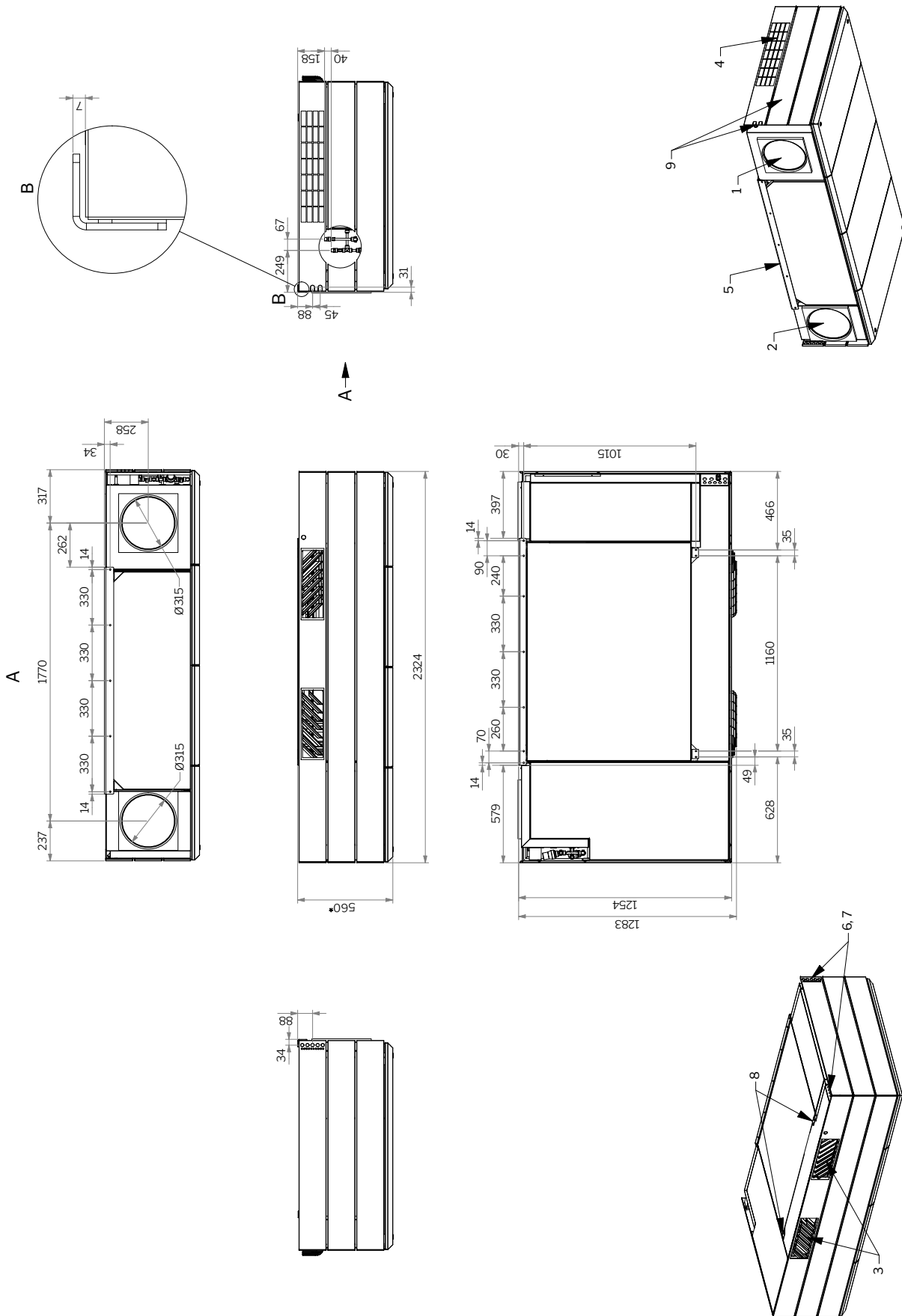

- 1 = Exhaust
  - 2 = Supply
  - 3 = Inlet
  - 4 = Extract
  - 5 = Wall-/ceiling frame
  - 6 = Condensate drain
  - 7 = Electrical connections
  - 8 = Ceiling fittings
  - 9 = DELIVERY + RETURN
- \* The unit's height is increased to 600 mm if the optional built-in smoke detector is chosen.

# AM 1000 HH BB

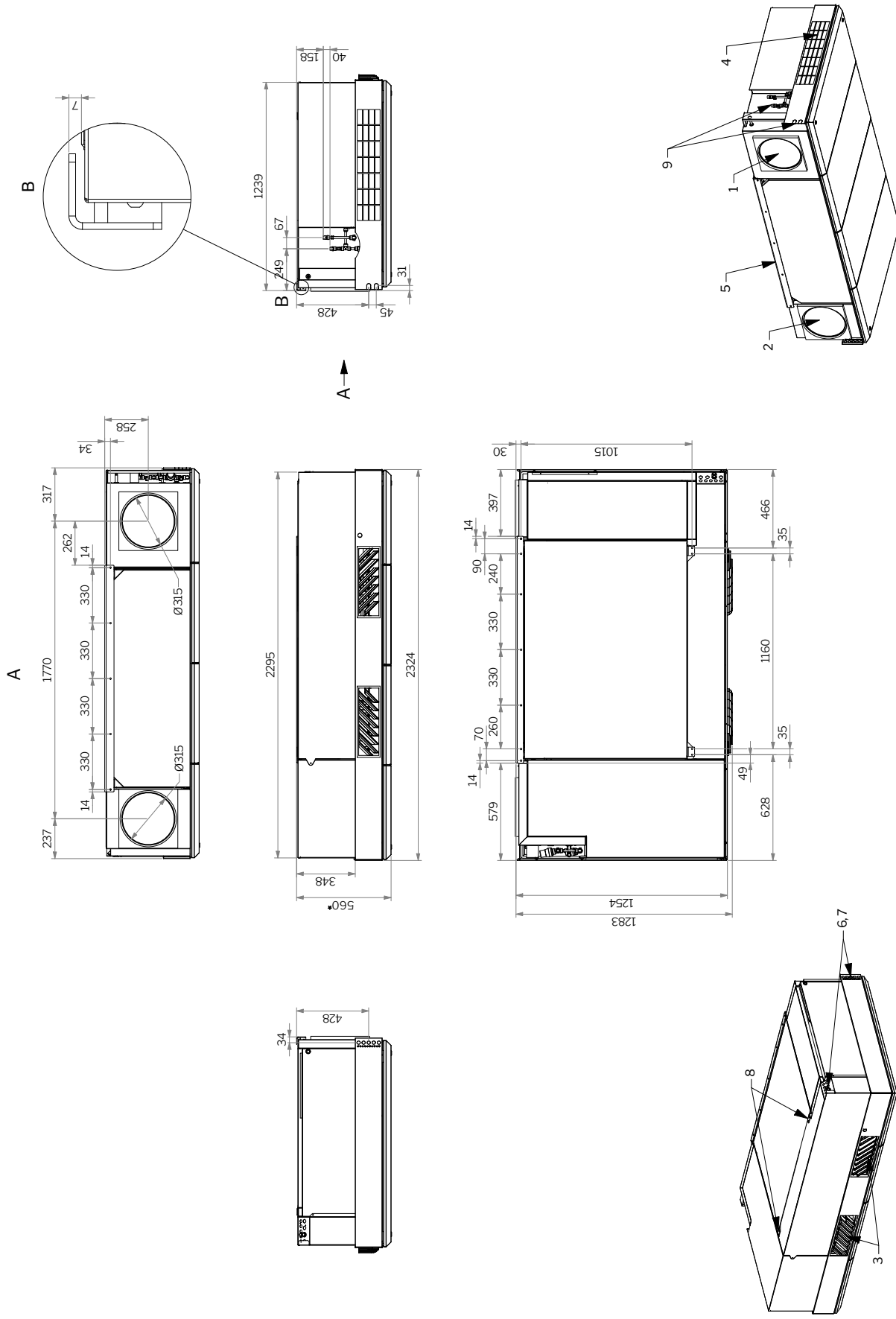

- 1 = Exhaust
  - 2 = Supply
  - 3 = Inlet
  - 4 = Extract
  - 5 = Wall-/ceiling frame
  - 6 = Condensate drain
  - 7 = Electrical connections
  - 8 = Ceiling fittings
  - 9 = DELIVERY + RETURN
- \* The unit's height is increased to 600 mm if the optional built-in smoke detector is chosen.

# AM 1000 HH DIDE

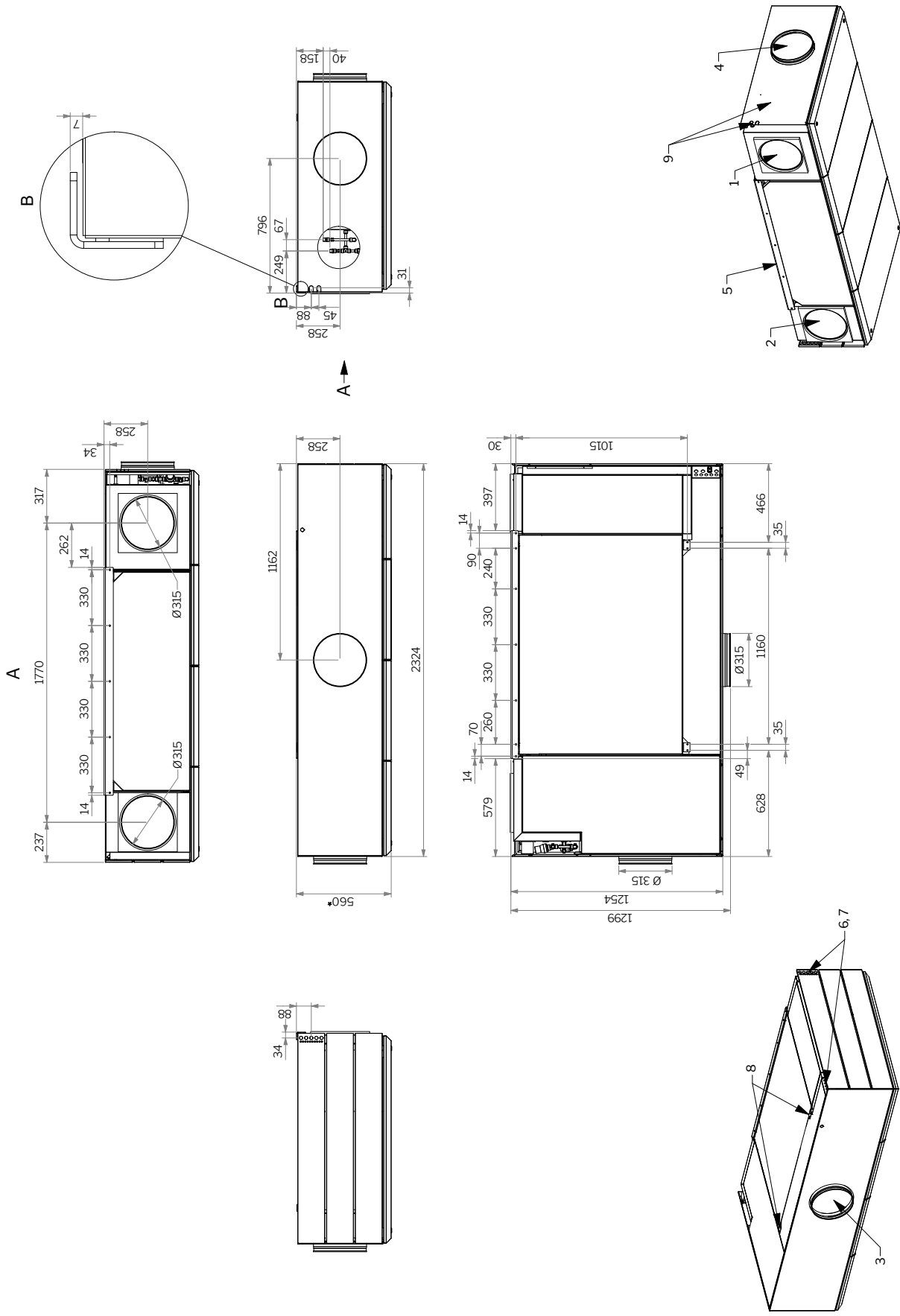

- 1 = Exhaust
  - 2 = Supply
  - 3 = Inlet
  - 4 = Extract
  - 5 = Wall-/ceiling frame
  - 6 = Condensate drain
  - 7 = Electrical connections
  - 8 = Ceiling fittings
  - 9 = DELIVERY + RETURN
- \*The unit's height is increased to 600 mm if the optional built-in smoke detector is chosen.

# AM 1000 HV TB

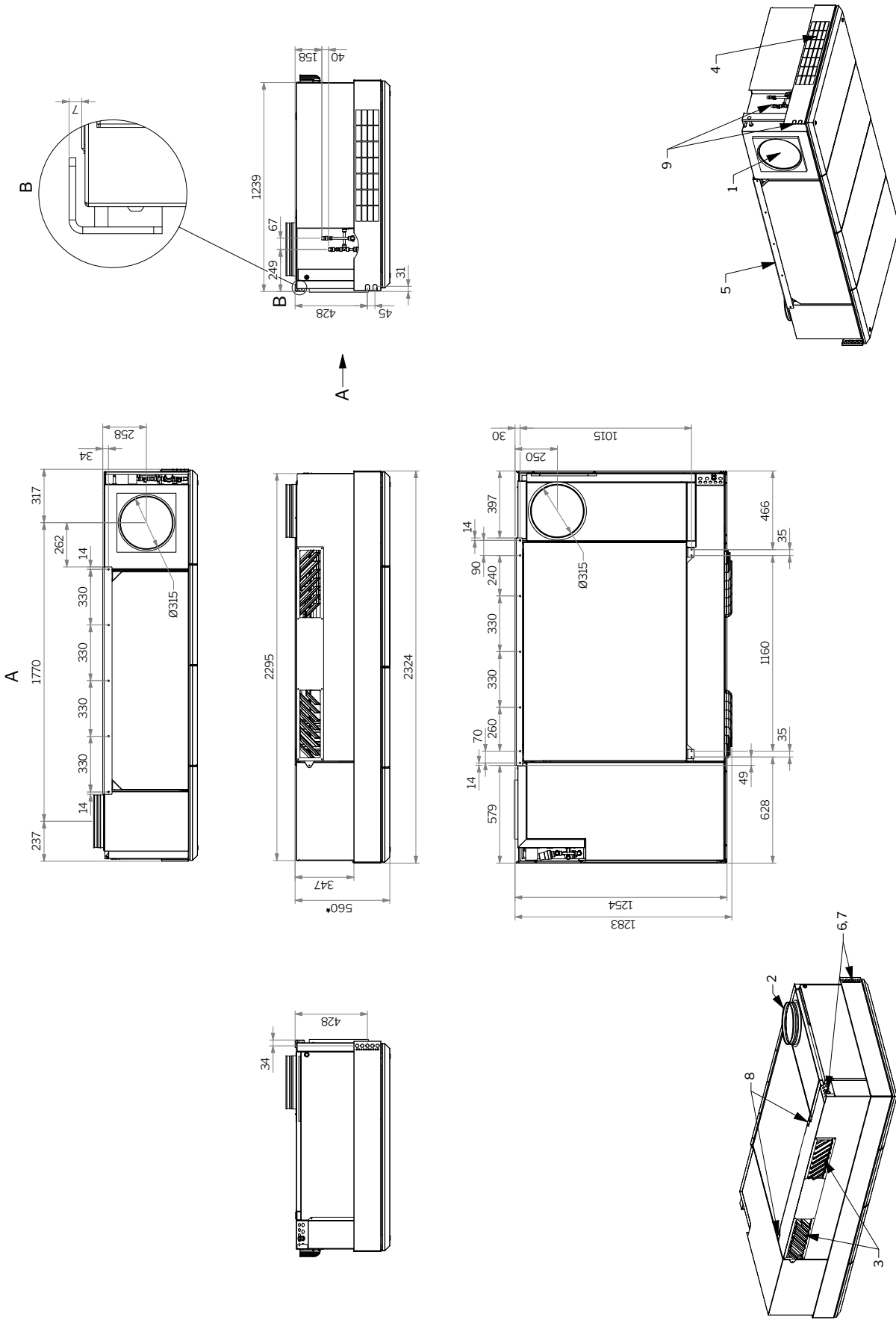

- 1 = Exhaust
  - 2 = Supply
  - 3 = Inlet
  - 4 = Extract
  - 5 = Wall-/ceiling frame
  - 6 = Condensate drain
  - 7 = Electrical connections
  - 8 = Ceiling fittings
  - 9 = DELIVERY + RETURN
- \* The unit's height is increased to 600 mm if the optional built-in smoke detector is chosen.

# AM1000 VV TT

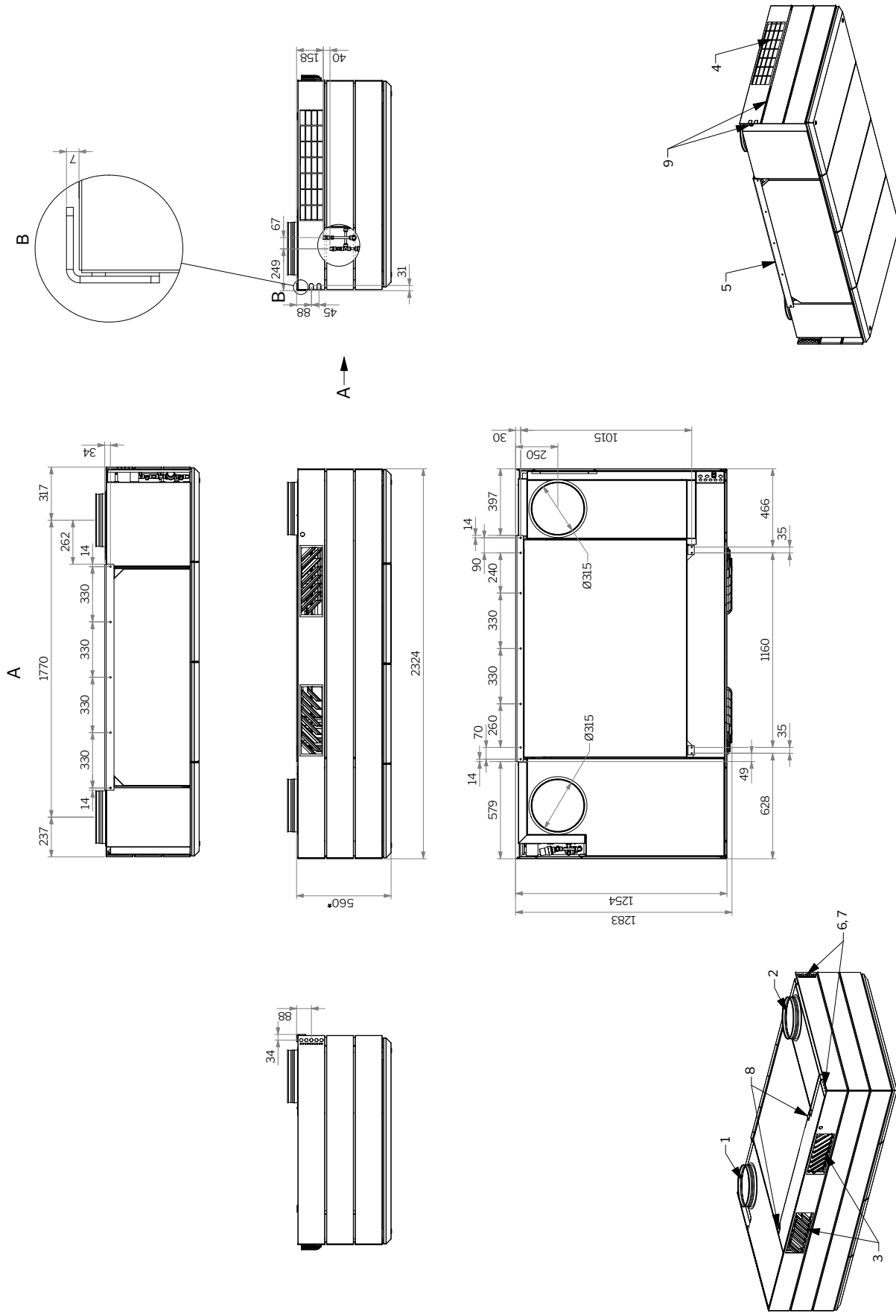

- 1 = Exhaust
  - 2 = Supply
  - 3 = Inlet
  - 4 = Extract
  - 5 = Wall-/ceiling frame
  - 6 = Condensate drain
  - 7 = Electrical connections
  - 8 = Ceiling fittings
  - 9 = DELIVERY + RETURN
- \* The unit's height is increased to 600 mm if the optional built-in smoke detector is chosen.

# AM 1000 VV BB

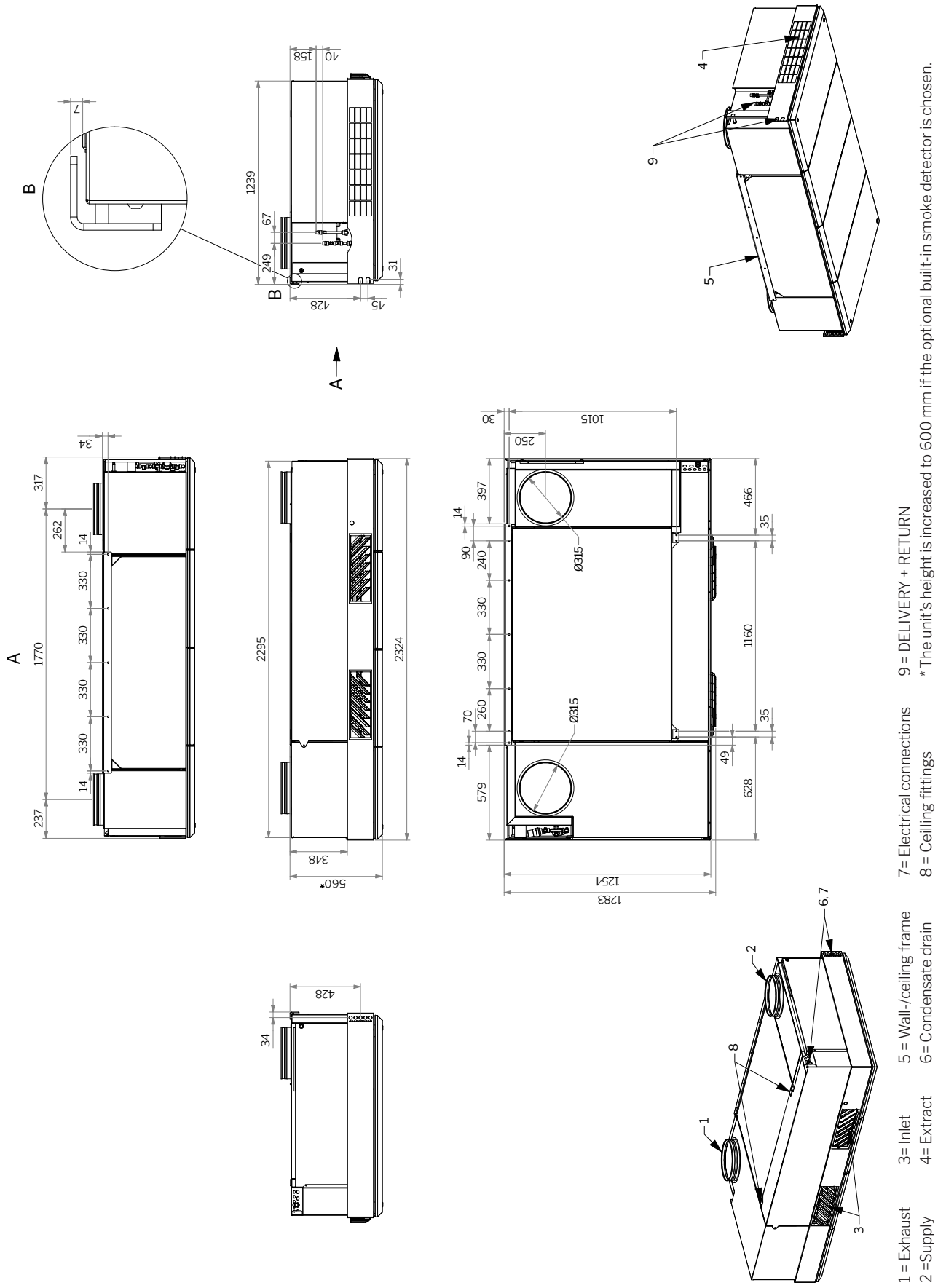

# AM 1000 VV DE

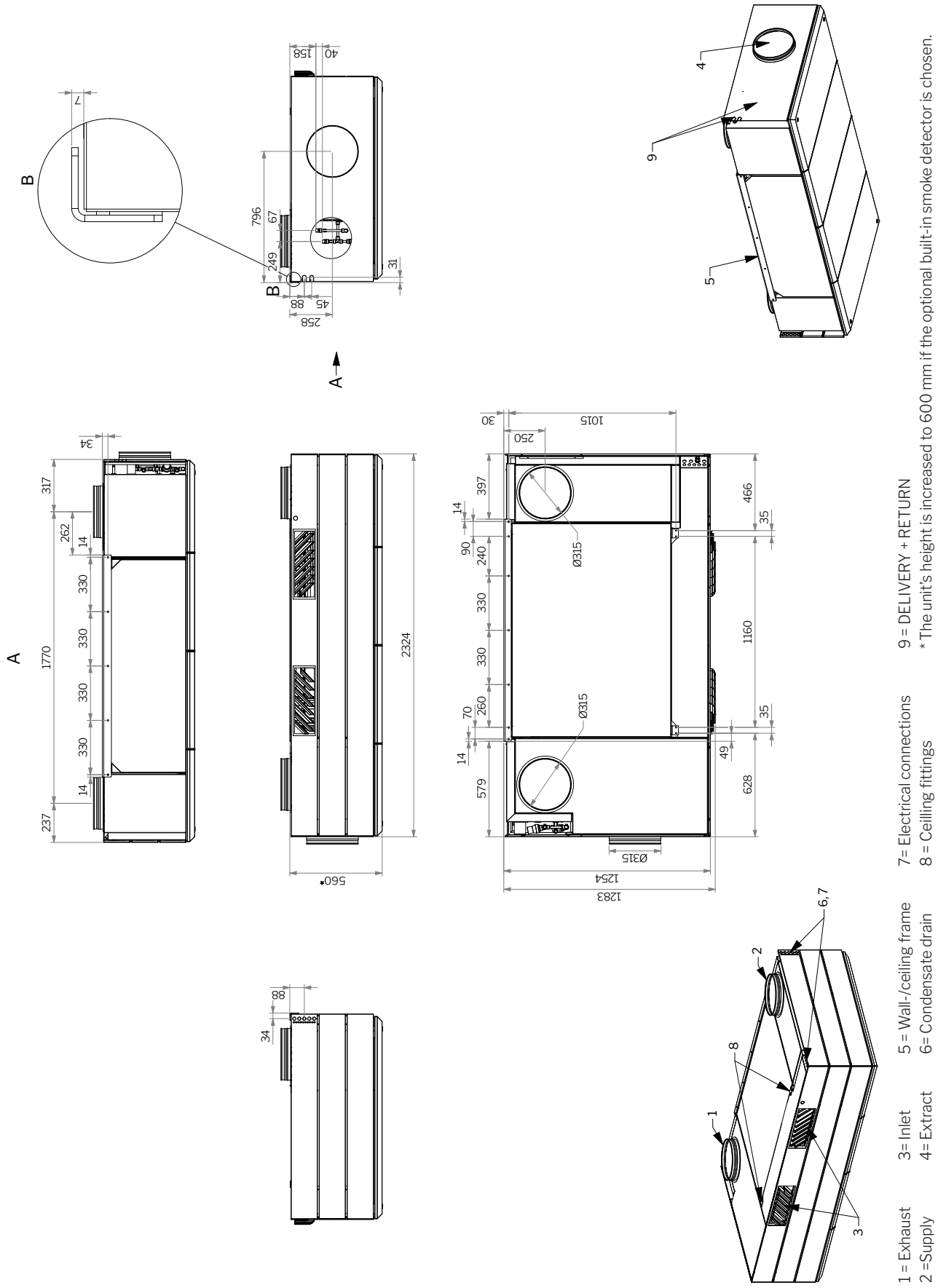

- 1 = Exhaust
  - 2 = Supply
  - 3 = Inlet
  - 4 = Extract
  - 5 = Wall-/ceiling frame
  - 6 = Condensate drain
  - 7 = Electrical connections
  - 8 = Ceiling fittings
  - 9 = DELIVERY + RETURN
- \* The unit's height is increased to 600 mm if the optional built-in smoke detector is chosen.

# AM 1000 S1S2 BB

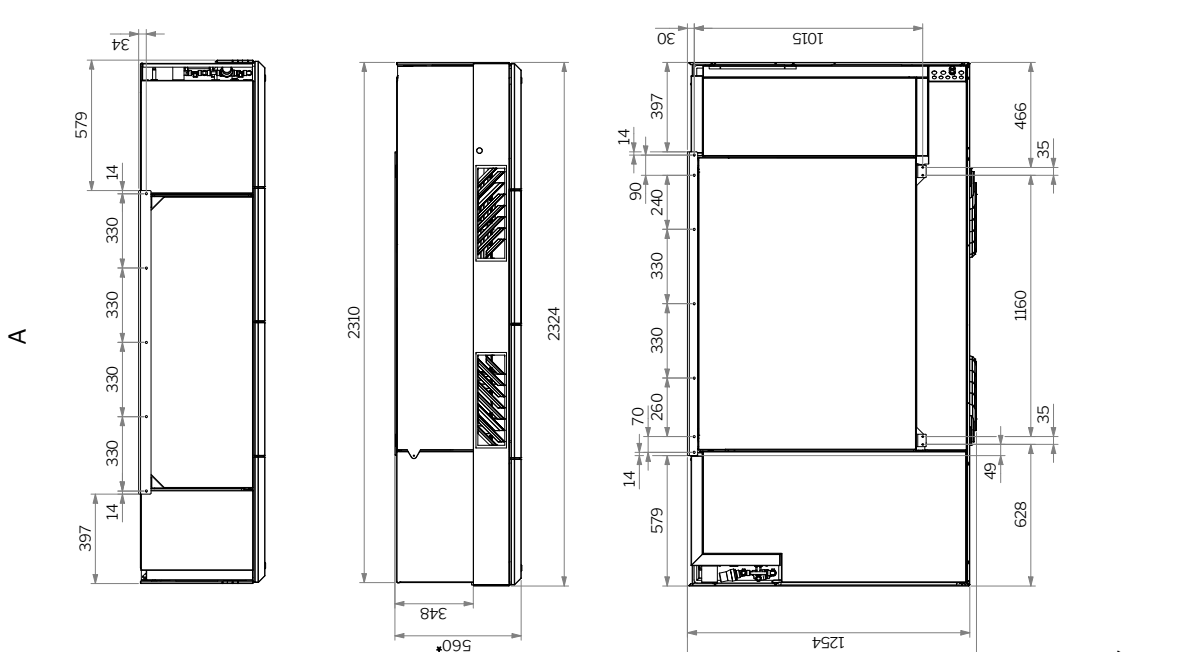
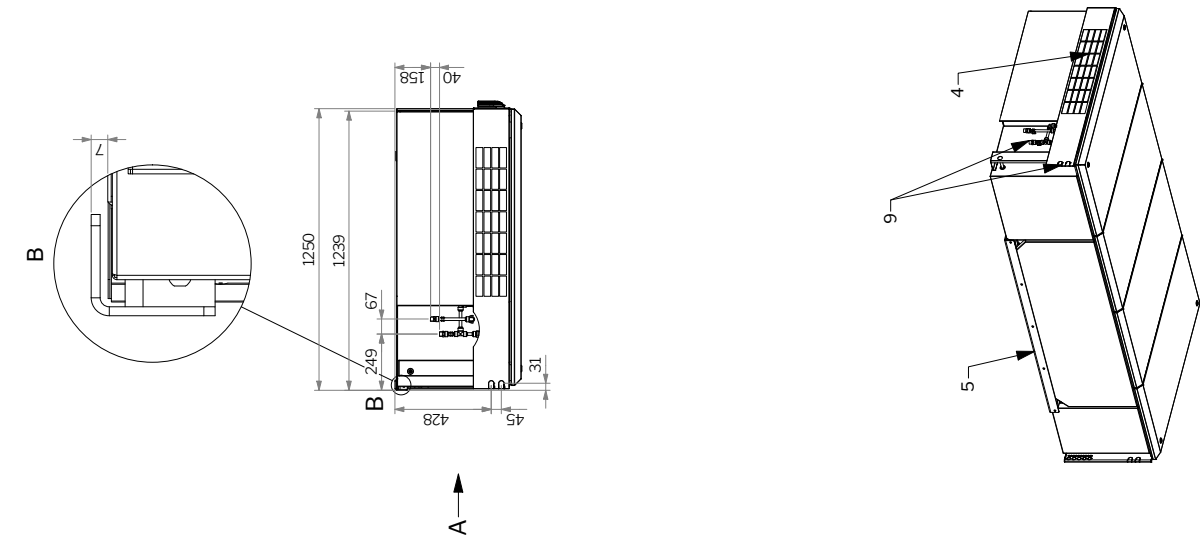

- 1 = Exhaust
  - 2 = Supply
  - 3 = Inlet
  - 4 = Extract
  - 5 = Wall-/ceiling frame
  - 6 = Condensate drain
  - 7 = Electrical connections
  - 8 = Ceiling fittings
  - 9 = DELIVERY + RETURN
- \* The unit's height is increased to 600 mm if the optional built-in smoke detector is chosen.



## Version overview

### Exhaust and supply position

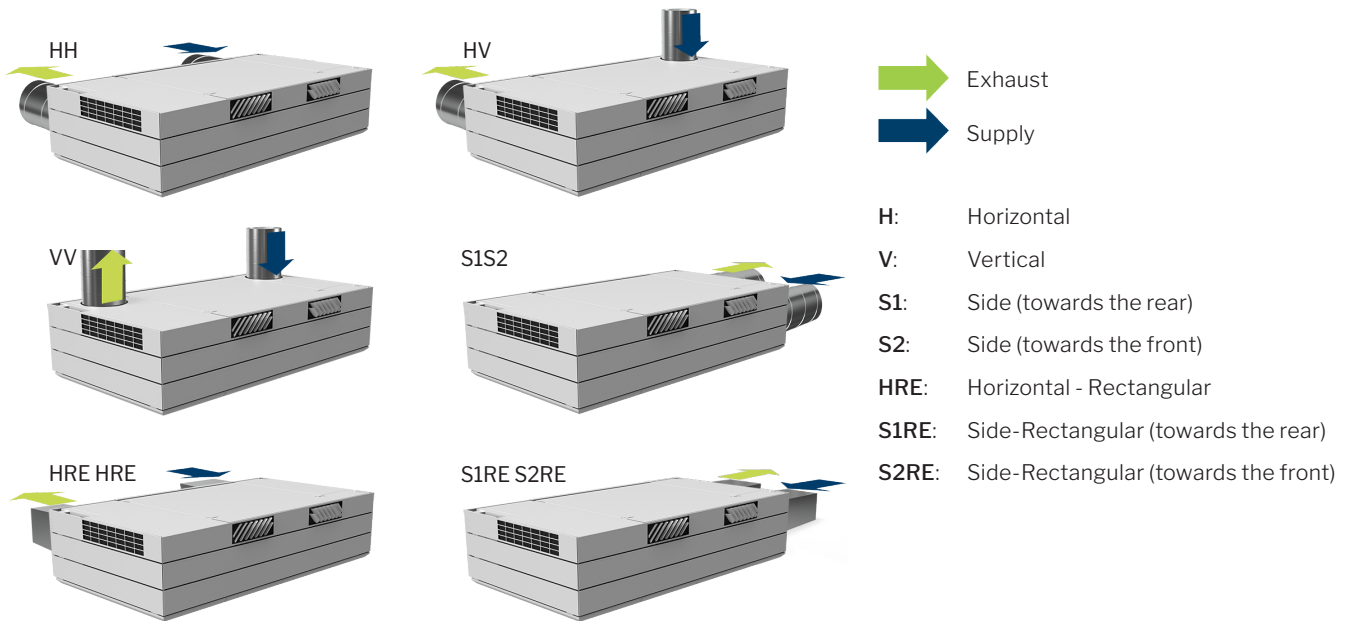

### Inlet and extract position

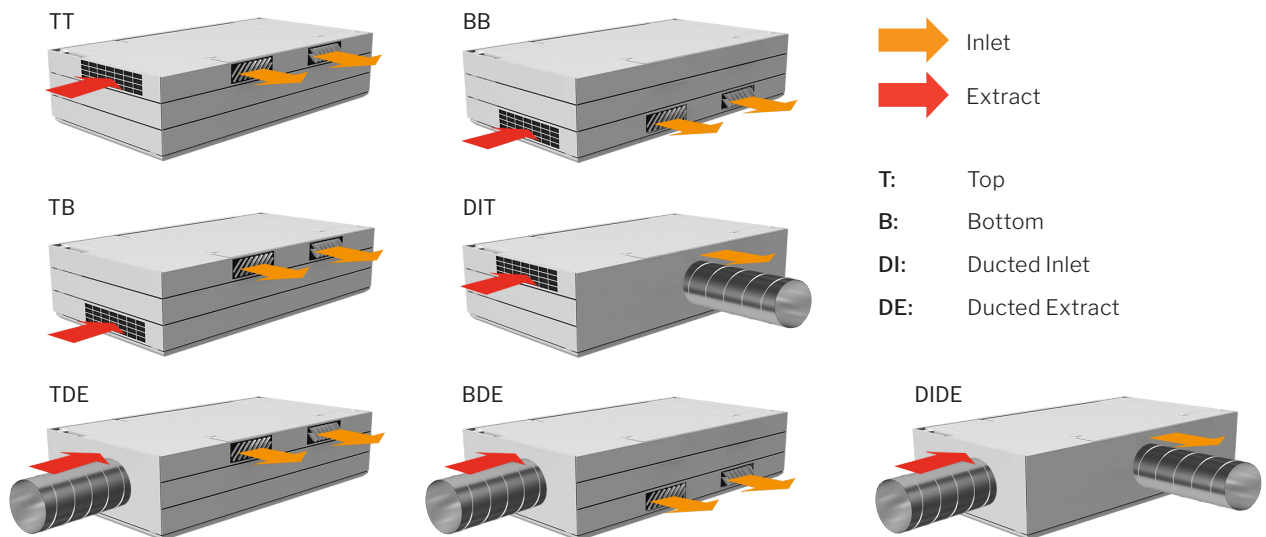

# Holes to be drilled for air ducts (HV, VV)

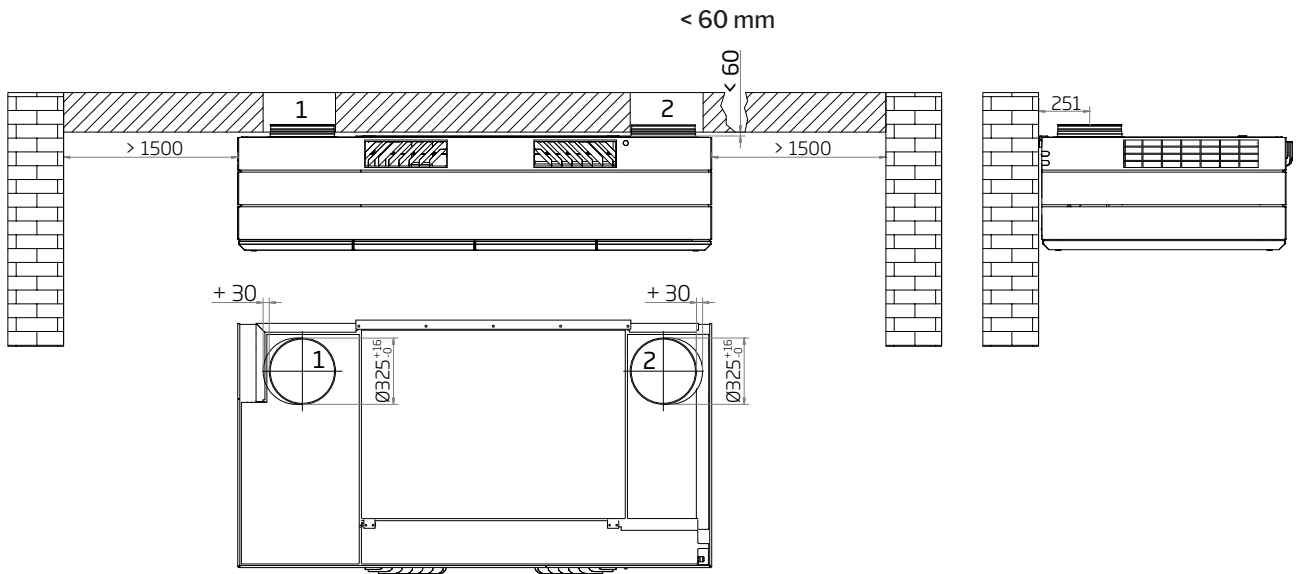

1 = Exhaust  
2 = Supply

# AIRMASTER