

The background features a light gray gradient with two large, overlapping, wavy patterns composed of many thin, parallel lines. One wave starts from the top right and curves towards the center, while the other starts from the bottom left and curves towards the center, creating a sense of motion and depth.

Operation & Maintenance

AM 150 | AM 300 | AM 500 | AM 800 | AM 900 | AM 1000 | AM 1200

AIRMASTER

SAFETY INSTRUCTIONS



This manual must be read before using the Airmaster air handling unit. Compliance with the manual ensures correct use of this product.

The manufacturer reserves the right to make changes without notice. All values stated are nominal values and can be affected by local conditions.

When using the unit in a room with a fire or stove drawing air from the room, all applicable provisions must be observed.

Failure to observe the warnings indicated by a danger symbol implies a risk of personal injury or damage to property.

The unit should not be used in rooms with abrasive particles or flammable or corrosive gas in the air, in wet rooms or explosion-protected rooms.

This guide relates to the Airmaster unit it accompanies plus all equipment, and must be given to and saved by the unit's owner.

The unit should not be used without the filters specified in this manual.

All necessary data and guides to network integration can be downloaded from www.airmaster-as.com.

The manufacturer cannot be held liable for damage arising from use in contravention of these instructions.

WARNINGS



The unit must be disconnected from mains electricity and precautions taken against accidental use before service covers can be opened.



The unit may not be started up until all service covers and grates on duct connections have been installed.



The installer must wear personal protective safety equipment, such as safety shoes, during the installation of the unit

Place of installation and serial numbers (S/N):

Type: _____

Delivery date: _____

Place of installation: _____

S/N of Air handling unit: _____

S/N of Cooling Module: _____

Table of Contents

1. Airlinq®	5
2. Function Principle	5
3. Airlinq Viva (White Control Panel)	6
3.1. Control Elements	6
3.2. Operation.....	6
3.2.1. Automatic Operating Lock.....	6
3.2.2. Child Lock.....	6
3.2.3. Start, Standby and Switch Off	7
3.2.4. Air Flow - Manuel Setting.....	8
3.2.5. Holiday Mode - Activation.....	9
3.3. Warning and Alarm.....	9
Reset Service.....	10
4. Airlinq Orbit (Black Control Panel)	11
4.1. Control Elements	11
4.2. Operation.....	11
4.2.1. Automatic Operating Lock.....	11
4.2.2. Air Flow - Manuel Setting.....	12
4.2.3. Automatic Operation.....	13
4.2.4. Operating Menu.....	13
4.2.4.1. Start and Standby.....	13
4.2.4.2. Off.....	14
4.2.4.3. Holiday Mode - Activation	14
4.2.4.4. Status	14
4.2.4.5. Setup.....	17
Timers	17
Date and Time.....	19
Default Flow	19
Default Temp.....	19
High Temperature	19
Reset Service.....	19
Data Log	19
Startup Guide	20
4.2.4.6. Lock Screen	20
4.2.5. Indoor Climate Level.....	20
4.2.6. Airlinq BMS.....	21
4.2.6.1. Control and setting.....	22
Select a Group/Unit.....	22
Start, Standby and Switch Off.....	22
4.3. Warning and Alarm.....	23
5. Airmaster Airlinq® Online	24

6. LED signals.....	25
7. Control functions.....	26
7.1. Timer-controlled ventilation	26
7.2. Night time cooling.....	26
7.3. Holiday mode.....	26
7.4. Start and stop using external contacts.....	26
7.4.1. Built-in smoke detector (optional).....	26
7.5. Start and stop using a PIR sensor	27
7.6. Control using a CO ₂ sensor og a CO ₂ / TVOC sensor.....	27
7.7. Boost.....	28
7.8. Control using an analogue BMS	28
7.9. Cooling module operation.....	28
8. Internal control functions	28
8.1. Low temperature (“Low Temp”).....	28
8.2. Preheat	28
8.3. Virtual preheat	29
8.4. High temperature (“High Temp”).....	29
9. Service and maintenance.....	30
9.1. External cleaning	30
9.2. Internal cleaning.....	30
9.3. Cleaning the condensate system.....	30
9.4. Filter change.....	31
9.4.1. Reset service (filter change).....	31
9.4.2. Cooling module filter change.....	31
9.4.3. Filter change for AM 150, 300, 500, 800, 1000.....	32
9.4.4. Filter change AM 900 and AM 1200	33
9.5. Filter list	35
9.6. Smoke detector (optional built-in)	36
9.7. Setting inlet air grille	37
9.8. Safety Instructions Cooling Modules.....	39
10. Repairs and Improvements.....	39
11. Dismounting	39
12. Disassembly.....	39
13. Disposal.....	39
14. Error Description.....	40
Abbreviations	41
Product Information According to DIRECTIVE 2009/125/EC.....	42

1. Airlinq®

Airmaster focuses not only on the air handling unit, but also on the control system software and operation. Airlinq is Airmaster's own unique ventilation control system, which gives the user and service technician impressive overview and full control over the indoor climate, plus easy access to a host of functions, which ensure correct operation of Airmaster air handling units.

Airlinq consists of a self-explanatory, intuitive control panel, Airlinq Viva (white) or Airlinq Orbit (black) and an integrated control box (AQC L or AQC P, black or grey box), designed to control all functions and equipment in the air handling unit supplied.

Operating the system using the Airlinq Viva control panel is described on pages 5 to 10, Airlinq Orbit from pages 11 to 23 and Airmaster Airlinq® Online on page 24.

The system can be connected to a PC using Airmaster programs "Airlinq User Tool" (corresponds to operating with Airlinq Orbit) for comfortable operation, or "Airlinq Service Tool" (only for service technicians) for programming and maintenance.

Airlinq's primary functions are:

- Controlling air flow and inlet temperature.
- Manual control.
- Timer-controlled operation using a timer.
- Unrestricted night time cooling for reducing room temperature during the night.
- Programmed operation using sensors (e.g. a Passive Infrared (PIR) and carbon dioxide (CO₂) sensors), analogue (A-BMS) and digital Building Management System (D-BMS).
- De-icing function and control of preheating surface and comfort heater for unit operation at low outside temperatures.
- Control of cooling module operation at high outside or room temperatures.
- Monitoring of the unit's temperature, components and air flow.
- Alarm functions for maintenance or fault.
- Control of up to 20 individual air handling units via a single control panel in an Airlinq BMS system, with sensors connected as required.
- Continuous and timed data log, which can be transferred to PC.
- PC connection to the Airlinq Viva and Airlinq Orbit control panels or to the control unit (AQC).

2. Function Principle

The diagram below shows the basic function of an Airmaster air handling unit.

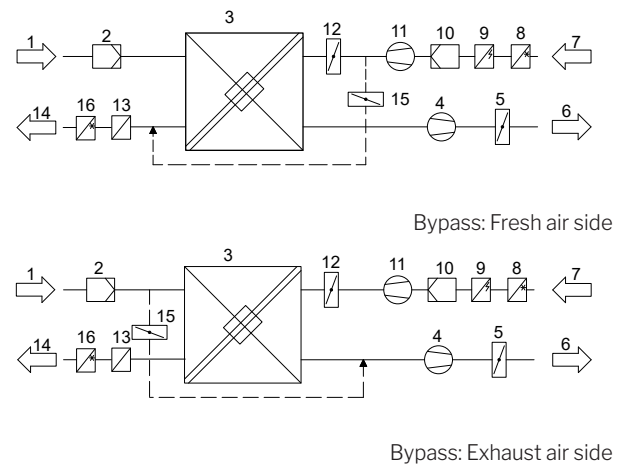

1. Extract air (waste air from the room).
2. Extract air filter.
3. Counter-current heat exchanger(s): heat exchangers effectively transfer heat energy from the extract air to the supply air.
4. Extract air fan.
5. Motorized exhaust air damper: shuts off the extract air path when the unit is stopped.
6. Exhaust air.
7. Supply air (fresh air form outside)
8. Cooling module CC (option, not available with all models): the cooling module reduces the outside air temperature before the air passes into the air handling unit.
9. Preheating surface (option): supports the de-icing function.
10. Supply air filter.
11. Supply air fan.
12. Motorised supply air damper: shuts off the supply air path when the unit is stopped.
13. Comfort heater (option): equalises the minor temperature loss in the heat exchanger (pos. 3).
14. Inlet (supply of heated outside air).
15. Modulating bypass: the bypass damper is used to regulate the inlet air temperature.
16. Cooling module RC (option, only available with AM 1000 models): the cooling module reduces the supply air temperature before the air enters the room.

The air temperature is monitored in the unit before and after the heat exchanger in the extract air path and the supply air path.

The outside and cooling circuit temperatures are monitored in the cooling module.

3. Airlinq Viva (White Control Panel)

3.1. Control Elements

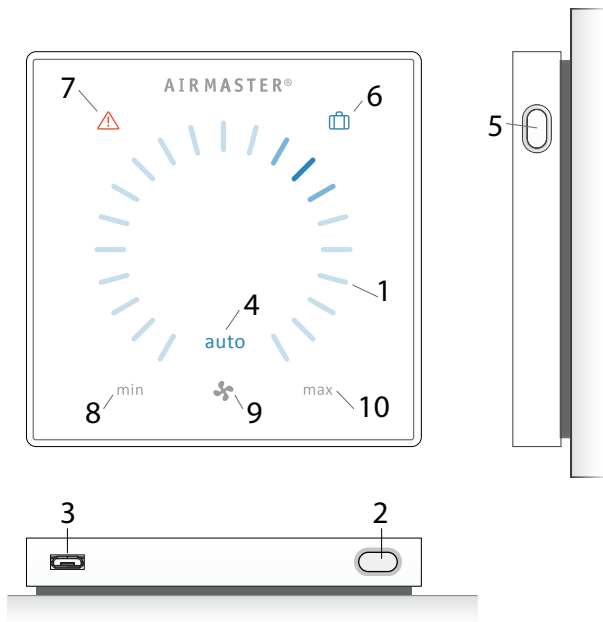

1. Air flow setting (blue light) using a touch sensitive control area, see page 8.
2. Function button (manual start, manual stop, manual temporary stop), see page 7.
3. USB mini-B port. To set or programme the air handling unit, a PC is connected with "Airlinq User Tool" or "Airlinq Service Tool" loaded. Download "Airlinq User Tool" and "Airlinq Service Tool" at:
www.airlinc.eu
4. Symbol "auto" for automatic operation (blue), see page 7.
5. Holiday mode button, see page 9.
6. Symbol for holiday mode (blue), see page 9.
7. Symbol for warnings (amber) and alarms (red), see page 9.
8. Text "min" for minimal air flow.
9. Fan symbol.
10. Text "max" for maximum air flow.

3.2. Operation

3.2.1. Automatic Operating Lock

The control panel is fitted with an automatic operating lock to prevent accidental air flow setting, e.g. during cleaning.

The lock activates automatically after 30 seconds of no operation.

Cancel automatic operating lock:

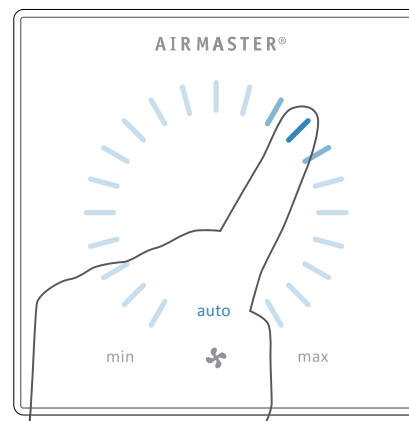

Press for 1 second on the current air flow.

>> The automatic operating lock will cancel when the air flow display is marked up to the current setting by blue stripes.

3.2.2. Child Lock

The child lock prevents all operation. Operation of functions with the child lock active will trigger 2 flashes of all blue stripes on the air flow display (Pos. 1 under "Control Elements" on page 6).

Activate/cancel child lock:

Press "Function button" and "Holiday mode button" simultaneously for 4 seconds (Pos. 2. and 5. under "Control Elements" on page 6).

>> All blue stripes on the air flow display will flash twice.

>> If operation is attempted with the child lock on, all blue stripes on the air flow display will flash twice.

3.2.3. Start, Standby and Switch Off

Airmaster's air handling unit can be started and stopped automatically or using the function button (pos. 2. under "Control Elements" on page 6).

Automatic operation.

Automatic operation is started using a timer, night time cooling, sensors, external contacts or an analogue BMS system.

The current air flow and text "auto" are shown on the control panel with a blue light above the fan symbol. (See 1st graphic below.)

Read also "Control System Functions" on page 26.

Air flow can be over- or overridden manually. Automatic operation is cancelled and the text "auto" will disappear.

1.



1. Start or restart automatic operation.

Press the function button.

>> The unit will start according to its programming if a start signal is active. The control system will reactivate automatic operation after manual override. The current air flow will be shown by a blue stripe. "Auto" will be shown with a blue light.

Start operation manual.

Double press the function button.

>> The unit will start with standard air flow and standard inlet air temperature (see page 19). "Auto" will be shown with a blue light. After 4 hours (time can be adjusted to 0, 1, 2, ... 255 hours using a PC with Airlinq Service Tool loaded) the unit will return to automatic operation.

2.



2. Standby:

Press the function button when the unit is in operation.

>> The unit will stop for 1 hour (time can be adjusted to 0, 1, 2, ... 255 hours using a PC with Airlinq Service Tool loaded) and then start at the next start signal. Otherwise, the unit can be started earlier by using the function button. The air flow indicator will flash slowly alongside minimum.

3.



3. Switch off the unit:

Press the function button for min. 2 seconds to switch off the unit.

>> The unit must then be started using the function button. All lights on the control panel will go out.

3.2.4. Air Flow - Manuel Setting

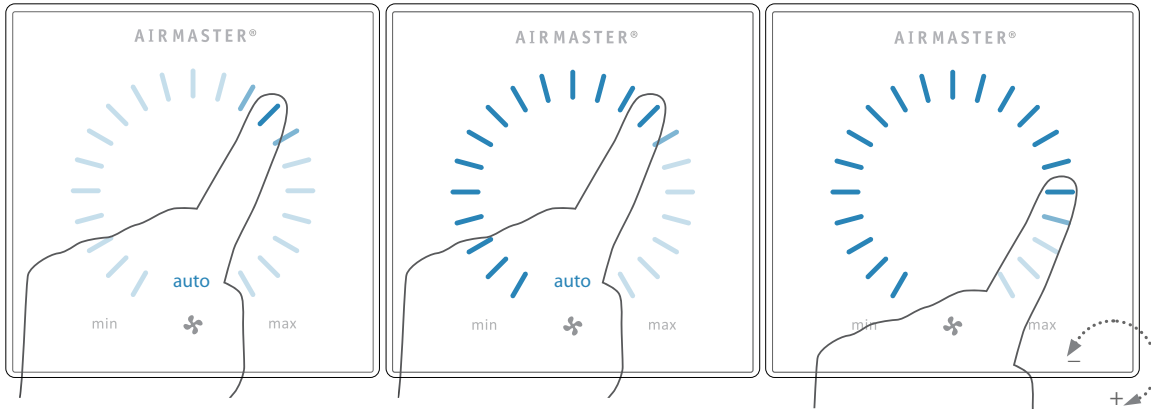

Press the current air flow. The automatic operating lock will cancel when the air flow display is marked up to the current setting by blue stripes.

Drag your finger on the setting area clockwise to increase air flow or counter clockwise to reduce air flow. The light will follow your movement.

Lift finger from the area when the required air flow is shown. The current setting will then be shown again with a single blue stripe.

After 12 hours (time can be adjusted to 0, 1, 2, ... 255 hours using a PC with Airlinq Service Tool loaded) the unit will return to automatic operation.

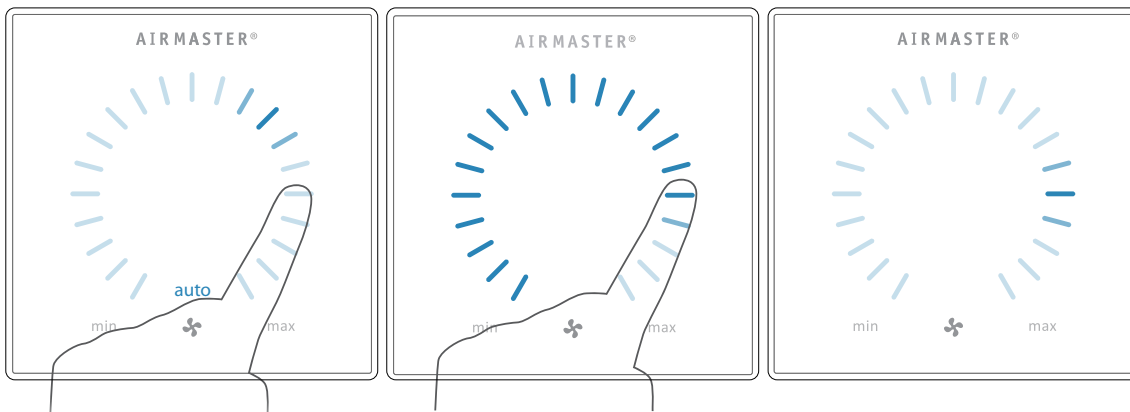

The same setting can be made by pressing the required air flow if the automatic operating lock is not active.

Lift finger from the area when the required air flow is shown. The current setting will then be shown again with a single blue stripe.

3.2.5. Holiday Mode - Activation

Holiday mode is used as basic ventilation when the room is unused for an extended period, e.g. holidays.



In holiday mode, the air handling unit will run with min. air flow. The internal control function “Low temperature” is active to protect the unit against ice formation. The control function is able to activate the heating surfaces if necessary. The internal control function “High temperature” is deactivated in holiday mode.

See also “Internal Control Functions” on pages 28 and 29.

Activate holiday mode.

Press holiday mode button (pos. 5. under “Control Elements” on page 6) for 2 seconds.

>> The unit will go into holiday mode.

Cancel holiday mode:

Press the function button (pos. 2. under “Control Elements” on page 6).

>> The unit will return to automatic operation.

3.3. Warning and Alarm

The Airlinq control system monitors temperatures, air-flow, cooling module function, filter status and various components.

In the event of a fault, the control panel will show a yellow or red symbol. The unit will maintain operation for yellow warnings as best it can, whilst it will stop for red alarms.

Warnings and alarms are shown by flashes at various intervals or a constant light. In the event of multiple faults, the faults will be shown with a brief pause in between each one.

Warning and alarm displays (yellow and red):



Light signals for warnings and alarms:

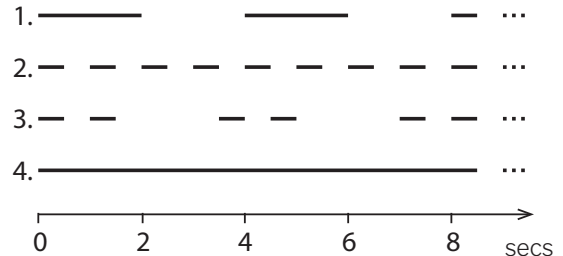

1. Slow flash (2 seconds on 2 seconds off).
2. Rapid flash (0.5 seconds on, 0.5 seconds off).
3. Rapid double flash (0.5 seconds on, 0.5 seconds off, 0.5 seconds on) at 2 second intervals.
4. Light on constantly.

See explanation of fault types on next page.

Warning (yellow)

The air handling unit remains in operation in the event of a warning, but can deviate from standard operation.

1. Slow flash:

Condensate - There is condensate in the cooling module which has not been automatically removed. Module out of operation.

- Remove condensate manually from the condensate tray.
- Clean the condensate system (see page 30), or CALL SERVICE.

2. Rapid flash:

Cooling module compressor locked (stopped). Module out of operation. Condenser overheated for an extended period.

- Check whether the alarm cancels after power has been cut off to the unit or CALL SERVICE.

3. Rapid double flash at 2 second intervals:

Filter needs replacing. Operation will continue unchanged.

- Change filters and cancel service (see below) or CALL SERVICE.

Reset Service

After a regular service with filter change, the filter change timer must be reset.

Press **RESET SERVICE**.

>> Enter the code (Standard "9732") and confirm. See sect. "Lock Screen" on page 20.

4. Light on constantly.

Technical fault on temperature sensors (RT, OTV, OT, EVi, EVo or HG), flow control or CO₂ sensor. The cooling module will be out of action if faults OT, EVi, EVo or HG occur. Certain internal control functions are working insufficiently if faults RT and OTV occur.

- CALL SERVICE.

A key to abbreviations is given in section 'Abbreviations' on page 40. Warnings and alarms can also be read using 'Airlinq User Tool' or 'Airlinq Service Tool'.

Alarm (red)

The air handling unit will stop to prevent damage in the event of an alarm.

1. Slow flash:

Low temperature - Low outside temperatures can make it necessary to protect the unit against ice formation. In such instances, the low temperature alarm will activate. The unit will automatically try to start up once every hour if the start signal is still active.

2. Rapid flash:

Condensate - There is condensate in the air handling unit which has not been automatically removed.

- Remove condensate manually from the condensate tray.

Units with no condensate drain:

- If the alarm repeats, it may be necessary to install a condensate drain or pump. CALL SERVICE.

Units with condensate drain/pump:

- Clean the condensate system (see page 30), or call service.
- The water lock is wrongly fitted. Installation can be corrected by authorised experts.
- Condensate pump defective. CALL SERVICE.

3. Rapid double flash at 2 second intervals:

Filter change required.

- Change filters and cancel service (see page 31) or CALL SERVICE.

4. Light on constantly.

Critical fault on temperature sensors (IT, ETV) or a fan.

- CALL SERVICE.

4. Airlinq Orbit (Black Control Panel)

4.1. Control Elements

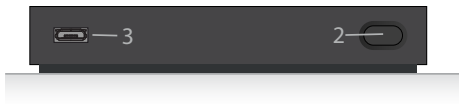

1. Air flow setting (blue stripes), see page 12.
2. Function button (activate control menu, switch off unit), see page 13.
3. USB mini-B port. Connection to PC using “Airlinq Service Tool”, to program the air handling unit. Download “Airlinq Service Tool” at:
www.airlinq.eu
4. Symbol for warnings (yellow) and alarms (red), see page 23.
5. CO₂ symbol, see “CO₂ Status” on page 23.
6. Text “min” for minimal air flow.
7. Fan symbol.
8. Text “max” for maximum air flow.
9. Touch screen, see page 11.

Other symbols

- “Auto”.
- “Start”.
- “Standby”.
- “Switch off”.
- “Confirm”.
- “Back”.
- “Cancel”.
- “Help”.
- “Selectable”

- “Selected”.
- “Increase” value.
- “Reduce” value.
- “Holiday mode” symbol shows for holiday mode instead of fan symbol (pos. 7.), see page 26.
- Padlock shows when operated with active automatic operating lock and active screen lock.
- “auto” “Automatic operation” text off when manual override or underride activated for air flow.

Touch screen

The Airlinq Orbit control panel is fitted with a touch screen operated in the same way as a smartphone. The control surface is 52 x 52 mm. To change the display view, scroll on either the left or right side of the control surface.

Screen displays and symbols adapt menus and functions automatically.

In sect. “Operation” from page 11 to page 23 only the most important content is shown on a white background is shown on all screens.

4.2. Operation

4.2.1. Automatic Operating Lock

The control panel is fitted with an automatic operation lock to prevent accidental operation, e.g. caused by cleaning.

The lock activates automatically after 120 seconds of no operation. The screen shows a padlock symbol with a directional arrow at the bottom if operated.

Activate operation:

Press padlock and drag in direction of arrow.



To lock the screen against accidental operation, see sect. “Screen Lock” on page 20.

4.2.2. Air Flow - Manuel Setting

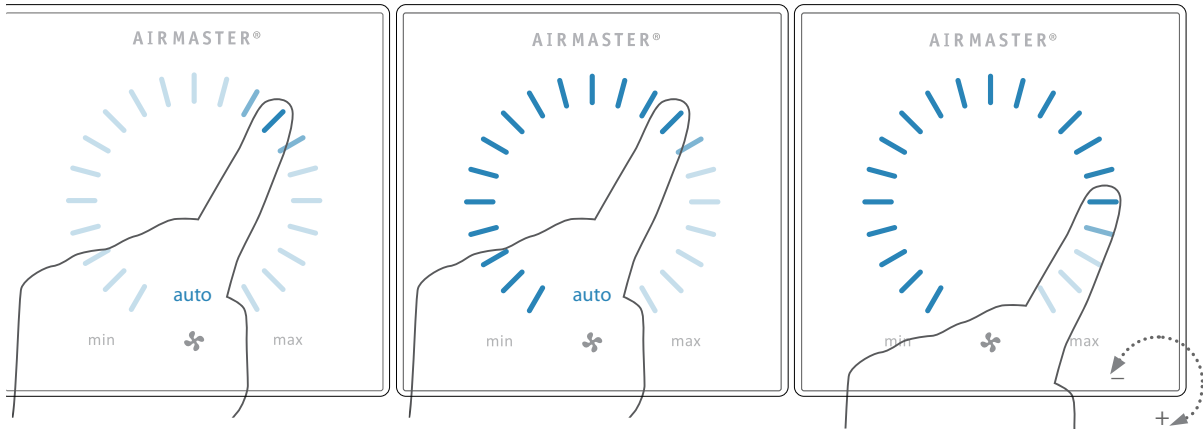

Cancel the operation lock or screen lock (if in use) and press the current air flow until the air flow display is marked up to the current setting with blue stripes.

Drag your finger on the setting area clockwise to increase air flow or counter clockwise to reduce air flow. The light will follow your movement.

Lift finger from the area when the required air flow is shown. The current setting will then be shown with 5 blue stripes.

After 12 hours (time can be adjusted to 0, 1, 2, ... 255 hours using a PC with Airlinq Service Tool loaded) the unit will return to automatic operation.



The same setting can be made by pressing the required air flow until the air flow display is marked up to the required setting with blue stripes.

Lift finger from the area when the required air flow is shown. The current setting will then be shown with 5 blue stripes.

4.2.3. Automatic Operation

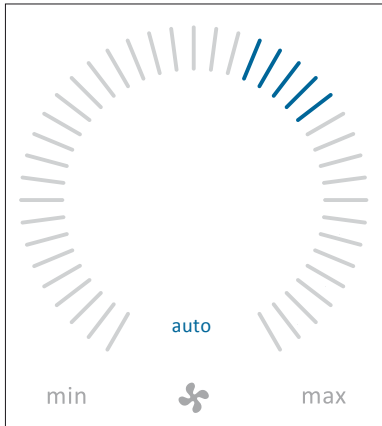

Automatic operation is started using a timer, night time cooling, sensors, external contacts or an analogue BMS system.

The current air flow and text "auto" are shown on the control panel with a blue light above the fan symbol.

Read also "Control Functions" on page 26.

Air flow can be over- or overridden manually. Automatic operation is cancelled and the text "auto" will disappear.

4.2.4. Operating Menu

Start the operating menu by pressing the function button (pos. 2 under "Control Elements" on page 11). Press a menu point to open the menu or activate/cancel a function. Depending on the menu, related function fields will also be changed. These can include text fields such as "Confirm", "Switch off", "Cancel" or fields with symbols. Pop-up texts can also appear for certain menus.

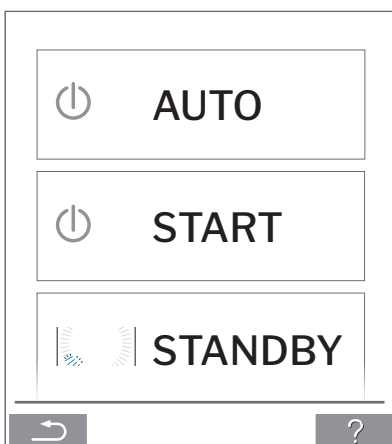

For group operation, see "Airlinq BMS" on page 21.

4.2.4.1. Start and Standby

Start or restart automatic operation.

Press menu field "AUTO".

>> The unit will start according to its programming if a start signal is active, or automatic operation will be reactivated after manual override. The current air flow will show with 5 blue stripes. Text "auto" will show with blue light.

Start operation manually.

Press menu field "START".

>> The unit will start with standard air flow and standard inlet air temperature (see page 19). Text "auto" will show with blue light. After 4 hours (time can be adjusted to 0, 1, 2, ... 255 hours using a PC with Airlinq Service Tool loaded) the unit will return to automatic operation.

Standby.

Press menu field "STANDBY", if the unit is in operation.

>> The unit will stop for 1 hour (time can be adjusted to 0, 1, 2, ... 255 hours using a PC with Airlinq Service Tool loaded) and then start at the next start signal. Otherwise, the unit can be started earlier by using the operating menu. The air flow indicator will flash slowly alongside minimum.

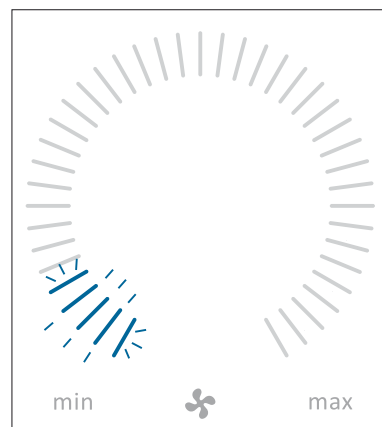

4.2.4.2. Off



Press menu field “ OFF”

>> The control panel will show “SHUTDOWN? AFTERWARDS THE SYSTEM HAS TO BE STARTED MANUALLY.”, a tick for “Confirm” or a cross for “Cancel”.

Press the tick to switch off. (The unit must then be started according to sect. “Start and Standby” on page 13. Press the cross to cancel switching off.

To switch off a unit, you can also press the function button for 2 seconds (pos. 2 under “Control Elements” on page 11).

4.2.4.3. Holiday Mode - Activation

In holiday mode, the air handling unit will run with min. air flow. The internal control function “Low temperature” is active to protect the unit against ice formation. The control function is able to activate the heating surfaces if necessary. The internal control function “High temperature” is deactivated in holiday mode.

See also “Internal control functions” on pages 28 and 29.

Activate Holiday mode:

Press menu field “ HOLIDAY MODE”

>> Holiday mode will activate. The holiday mode symbol will show instead of the fan symbol.

Deactivate holiday mode:

To deactivate holiday mode, the unit must be started according to sect. “Start and Standby” on page 13.

4.2.4.4. Status

The Status menu is divided into 6 groups: Information, Flow, Filters, Operation, Hardware and Installation Check. The menu points indicate the unit’s operational status.

Press menu field “ STATUS”

>> The sub-menu will activate.

Press the required sub-menu.

Information

Total Operation time

The unit’s operation hours since manufacture.

Panel SW

Control panel software version.

Control unit SW

Control unit software version.

Control unit Serial

Control unit serial number.

Service

Contact address for technical help and service. Can be changed using Airlinq Service Tool.

Flow

Requested Flow

Air flow in %.

Supply Air Flow

Supply air flow in m³/h.

Extract Air Flow

Extract air flow in m³/h.

Supply Air Fan

Supply air fan RPM.

Extract Air Fan

Extract air fan RPM.

Filters

Current filter state

Filter status indicator in %.

Operation since service

No. of operation hours since last filter change.

Next service

Forecast of hours to next filter change.

Approximated date

Forecast (date) of next filter change.

Operation

Started By	<p>Operation start signal</p> <ul style="list-style-type: none"> - “External”, using external contacts and relays. - “Airlinq”, manual start using a control panel. - “CO2”, using a CO2 sensor. - “PIR”, using a passive infrared sensor. - “BMS”, using an analogue or digital BMS system. - “Timer”, using a timer. - “Holiday mode”, via control panel or a digital BMS system. - “Dependent”, on several start signals.
Operation State	<p>Operation status</p> <ul style="list-style-type: none"> - “Automatic”, fully automatic operation according to programming. - “Manual”, when the automatically set air flow or inlet temperature is changed by the user or a BMS system. - “Night time cooling” is activated. - “Holiday mode” is activated. - “OFF”, the unit is switched off, and must be started using the control panel. - “Standby”, the unit is temporarily stopped and will start automatically according to programming.
System Condition	<p>Active internal control system function</p> <ul style="list-style-type: none"> - “Low temperature”. - “High temperature”.

See “Internal Control Functions” on page 26.

External Stop	Stop function status On/Off.
Inlet Temperature	Inlet temperature in °C.
Outside Temp. AHU	Outside temperature air handling unit in °C.
Room Temperature	Extraction temperature in °C.
Exhaust Temp. AHU	Exhaust temperature air handling unit in °C
Requested Temp.	Setpoint Inlet temperature in °C.

Operation

Max Room Temp.	Setpoint “High room temperature” in °C.
Pre Heater	Connected in %.
Comfort Heater	Connected in %.
Main Damper	Status On/Off.
Bypass Damper	Bypass position in %. (0 = closed; 100 = fully open)
Adaptive Airflow	Signal voltage Adaptiv Airflow® in Volts.
Supply Air Fan	Signal voltage supply air fan in Volts.
Extract Air Fan	Signal voltage extract air fan in Volts.
Cooling Module	Operation in %.
Evaporator temp.	Evaporator temperature in °C.
Condenser temp.	Condenser temperature in °C.
Setpoint Cooling Mod.	Cooling module temperature setpoint in °C.
Outside Temperature	Outside temperature cooling module in °C.
Evaporator in	Evaporator temperature “in” in °C.
Evaporator out	Evaporator temperature “out” in °C.
Hot Gas	Hot Gas temperature in °C.
Rel. humidity outside	Relative humidity (outside air) in %
Rel. humidity inside	Relative humidity (exhaust air) in %
AI#1	Analogue input 1 in Volts.
AI#2	Analogue input 2 in Volts.
AI#3	Analogue input 3 in Volts.

If an option is not installed, no operation value will show in the status menu.

Hardware

The condition of the individual components are monitored and displayed in this menu.

Component functional = "OK"

Component with fault = "Fault"

Component not programmed = "N/A"

Components monitored:

Room temperature	Room temperature sensor.
Inlet temperature	Inlet temperature sensor.
Outside temperature	Outside temperature sensor.
General.Purp.Temp.	General purpose temperature sensor.
Condenser Temp.	Condenser temperature sensor.
Evaporator Temp.	Evaporator temperature sensor.
Exhaust Temp. AHU	Exhaust temperature sensor air handling unit.
Outside Temp. AHU	Outside temperature sensor air handling unit.
Supply Air Flow Sens. 1	Supply air flow sensor 1.
Supply Air Flow Sens. 2	Supply air flow sensor 2.
Extract Air Flow Sensor	Extract air flow sensor.
CO2 Sensor	CO ₂ Sensor.
Supply Air Fan	Supply air fan.
Extract Air Fan	Extract air fan.
Evaporator In Temp.	Evaporator inlet temperature sensor.
Evaporator Out Temp.	Evaporator outlet temperature sensor.
Hot Gas Temperature	Hot gas temperature sensor.
CC Connection	Data connection to the cooling module.
CC Stepdriver	Step driver cooling module.
CC Frequency Inverter	Frequency inverter cooling module.
Humidity Sensor (out)	Humidity Sensor (outside).

Humidity Sensor (in)

Humidity Sensor (inside).

Installation Check

All units in the Airlinq system are identified and shown in the order it is programmed. The Installation check will show the following:

This Unit	Type of unit that shows the "Installation check"; PC or ID number of the control panel.
Expected AHU's	Number of air handling units expected in the system.
Online AHU's	Number of online air handling units.

Sub-menu "Online AHU'S"

Group "x", ID "y"	All groups complete with air handling unit ID (ID = identification number); x = 0, 1, 2, ... or 19, y = 0, 1, 2, ... or 19. If cooling modules are installed the text "+CC ID" is shown together with the identification number of the cooling module; 100, 101, 102, ... or 119
--------------------------	--

Sub-menu "Online Control Panels"

ID "z"	Identification number of all online control panels; z = 160, 161, 162, ... or 179.
---------------	--

Sub-menu "Group Master N/A"

Group "x", ID "y"	See description above.
--------------------------	------------------------

4.2.4.5. Setup

All operational parameters can be changed under the “**SETUP**” menu, according to local conditions. 

Timers

 **TIMER-CONTROLLED VENTILATION** and

 **NIGHT TIME COOLING**, set using the control panel or “Airlinq User Tool”, starts and stops the air handling unit using a timer. There are up to 7 different timer programs for timer-controlled ventilation. All programs can be active concurrently, and run after each other or override each other.

Detailed function description available on page 26.

PROGRAM DISPLAY

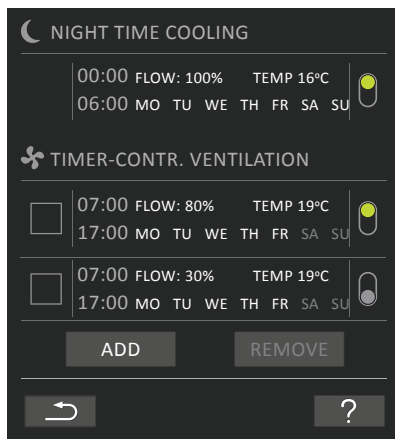

PROGRAMS DISPLAYED (examples)

Night time cooling:

Air flow (Flow) 100%,
Inlet temperature (Temp) 16 °C,
Start: 00:00, Stop: 06:00,
Days: All days of the week (MO, TU, ..., SA, SU),
Program active (green point).

Days for night time cooling cannot be adjusted.

Timer-controlled ventilation upper program:

Air flow (Flow) 80%,
Inlet temperature (Temp) 19 °C,
Start: 07:00, Stop: 17:00,
Days: Monday to Friday (MO, TU, WE, TH, FR shown in white text); Saturday and Sunday are programmed inactive (SA and SU shown in light grey text),
Program active (green point).

Timer-controlled ventilation lowest program:

Air flow (Flow) 30%,
Inlet temperature (Temp) 19 °C,
Start: 07:00, Stop: 17:00,
Days: Monday to Friday (MO, TU, WE, TH, FR shown in white text), Saturday and Sunday are programmed inactive (SA and SU shown in light grey text),
Program inactive (grey point).

Adjust a program

Press program.

>> Follow the guide on the next page.

Activate a program

Press the grey point on the right side of the program.

>> The point will change position upwards and go green.

The most recently activated timer program dictates operation of the air handling unit.

Deactivate a program

Press the green point on the right side of the program.

>> The point will change position downwards and go grey.

Add a program for timer-controlled ventilation

Press “Add”.

>> Follow the guide on the next page.

Remove a program from timer-controlled ventilation

>> Follow the guide on the next page.

Adjust or add a program:

After selecting the program to be adjusted, or use of the function button “Add” (see program view on previous page), ‘Setting’ mode will start.

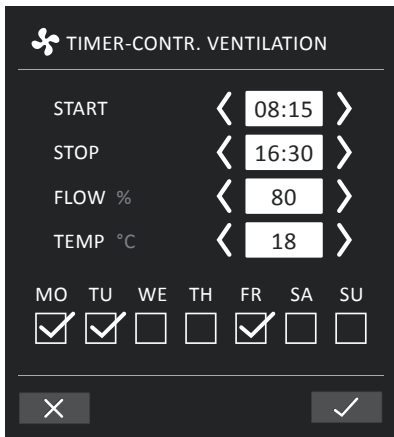

Increase/reduce a value:

Values can be set by pressing the right arrow (increase) or left arrow (reduce).

Operation days are marked with a tick.

Make all settings and confirm by pressing the tick.

>> The program will be adjusted/added.

>> Display will return to “Program view”.

(See page 17)

Press the cross to cancel adjustment/adding.

Temperature setting:

The standard inlet temperature (default temperature) is the setpoint for the unit’s required temperature level. Standard setting is 19°C. The temperature can be set to max. the required room temperature.

The Airmaster unit can not be used to heat a room by increasing inlet temperature. Room temperature regulation must be performed using a heater installed in the room.

Remove a program:

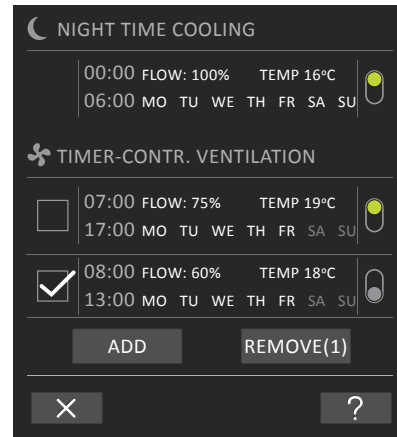

Programs for timer-controlled ventilation can be removed from the list.

Press the square on the left of the program to be removed.

>> The program will be marked with a tick. The function button “Remove” shows the number of programs to be removed.

Press the function button “Remove” to remove the programs selected or press the cross to cancel.

>> Programs will be removed.

>> Display will return to “Program view”.

(See page 17)

Program ‘Night time cooling’ cannot be removed.

Date and Time

Date and time are preprogrammed according to the calendar. Time changes automatically to summer and winter times. The summer/winter setting can be deactivated using the Airlinq Service Tool.

The control system software date and time synchronises automatically with date and time on a connected PC, but can also be set directly.

Press **Date** or **Time**.

>> Set date or time.

Default Flow

The standard air flow (Default flow) is used by the Airlinq control system when the air handling unit is started using sensors or external contacts.

Press Default Flow.

>> Set Default Flow in % (Default 80%).

Default Temp

The standard inlet temperature (default temp) is the setpoint for the unit's required temperature level. Standard setting is 19°C. The temperature can be set to max. the required room temperature.

The Airmaster unit can not be used to heat a room by increasing inlet temperature. Room temperature regulation must be performed using a heater installed in the room.

Press Default Temp.

>> Set inlet temperature in°C (Default 19 °C).

High Temperature

High temperature is programmed at 25°C. At this room temperature, the upper limit of the temperature range described as "comfort temperature" is exceeded.

If the unit detects that this limit is exceeded when in operation, its control system will start a cooling process to reduce the current room temperature. See "Internal Control Functions - High Temperature" on page 29.

This temperature setting does not generally need to be changed.

Press High Temperature.

>> Set high room temperature in°C (Default 25 °C).

To ensure trouble-free operation, we recommend programming high room temperature higher than the normal room temperature.

Reset Service

After a regular service with filter change, the filter change timer must be reset.

Press **RESET SERVICE**.

>> Enter the code (Standard "9732") and confirm. See sect. "Lock Screen" on page 20.

Data Log

Airmaster units have a continuous data log. When the memory is full, the oldest data is overwritten first.

If a fault is detected on the unit, a time-limited data log can be activated.

Press Data Log

>> Set log interval (log period is calculated automatically), or set log period (log interval is calculated automatically).
>> Activate data log - All data in the memory is deleted, and the data log started.

When the data log is completed, a pop-up text appears on the control panel:

"Time-limited data log completed. Download data to a PC with Airlinq Service Tool"

The log period depends on the logged parameters. In the event of rarely-occurring faults, the interval or period can be extended, and in the event of frequent faults, the interval can be shortened. After transfer to a PC, the data log can be automatically sent for analysis by (e.g.) your service partner.

Please contact your service partner by phone or mail to agree service provision.

Startup Guide

The startup guide starts automatically when the unit is started for the first time. The guide can also be started manually subsequently (menu under “Setup”), e.g. to retro-install a CO₂ sensor.

The most important settings can be made using the startup guide. The guide must be run completely. When making settings, the guide jumps automatically to the appropriate menu point and back.

Startup guide menu points:

- Set Default Flow, see page 19.
- Set Default Temp, see page 19.
- Set High Temperature, see page 19.
- Set Date and Time, see page 19.
- Set Night Time Cooling and Timer-Controlled Ventilation, see page 17.
- Set CO₂ level lower limit and upper limit and Start/ Stop of the unit with CO₂ sensor, see page 27.
- Set the code for the screen lock and the Service Reset, see page 20.
- Set the activation of the screen lock, see page 20.
- Start unit (starts the unit with the current programming and terminates the startup guide).

4.2.4.6. Lock Screen

The control panel can be locked to prevent accidental operation using the screen lock.

Activate screen lock:

Press “ LOCK SCREEN”.

>> The screen will lock immediately. The control panel will show the main screen.

The screen lock is protected by a 4 digit code (Default: “9732”). The code can be changed and the activation of the screen lock can be changed to manual, automatic or inactive by using the Startup Guide or the programs Airlinq User Tool and Airlinq Service Tool.

Deactivate the screen lock:

Press padlock on the control panel main screen and drag in direction of arrow.



Set code:

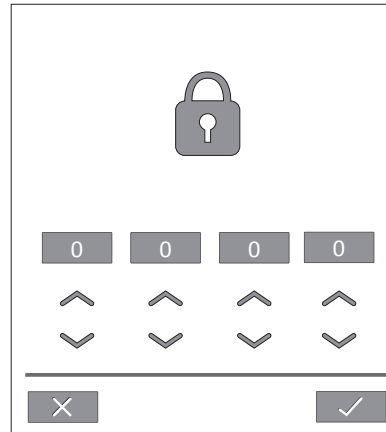

Set code by pressing the up arrow to increase the value, and down arrow to reduce it.

Press tick.

>> The screen will be unlocked.

4.2.5. Indoor Climate Level

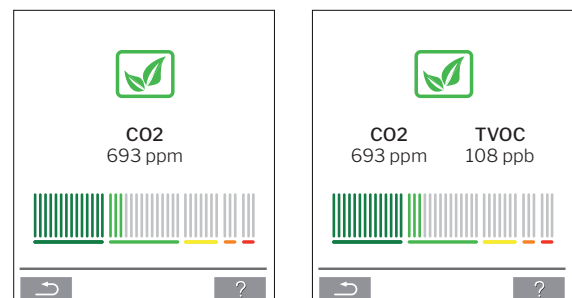

If the air handling unit is equipped with a CO₂ or CO₂/TVOC sensor, the room’s current indoor climate level will appear on the control panel.

When the sensor sends a signal to the air handling unit, the indoor climate symbol appears on the main menu of the control panel. Depending on the level, the symbol appears as dark green, light green, yellow, orange or red.

Press symbol (pos.5 under “Control Elements” on page 11).

>> The indoor climate status appears.

4.2.6.1. Control and setting

Each group in the system is controlled and set in the same way as an individual unit. That means that all control options are available for all groups. The status menu and alarm view are available for all individual units. A group or single unit can be selected for each screen. You can enter or leave the menu from all locations.

A "G" or "ID" number is allocated to each group or unit to identify which group/unit is being controlled. The G and ID numbers can be changed, e.g. to a room name or number using Airlinq Service Tool.

Grouping is performed when installing the system using Airlinq Service Tool.

Select a Group/Unit

The current identification for the group (G) or the unit (ID) will be shown at the bottom of the screen. E.g. G8 or ID16

Press "G8"/"ID16".

>> The selection screen will appear.

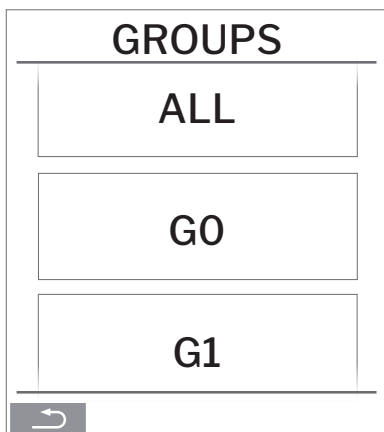

This screen shows all groups (G) or units (ID) linked to an Airlinq BMS. E.g. G0 to G10 and ID0 to ID16 if the system consists of 11 groups with a total of 17 units.

Press the G or ID required.

>> The screen for that G or ID will be shown.

Start, Standby and Switch Off

Start or restart automatic operation for a group/several groups

Press the function button.

>> The control menu will appear.

Select the groups to be started and press menu field "⏻ **AUTO**".

>> The group selected will start according to the programming.

Start operation manually.

Press the function button.

>> The control menu will appear.

Select the groups to be started and press menu field "⏻ **START**".

>> The group will start with standard air flow and standard inlet air temperature (see page 19). Text "auto" will show with blue light. After 4 hours (time can be adjusted to OFF, 0, 1, 2, ... 255 hours using a PC with Airlinq Service Tool loaded) or at the next stop signal from a timer program, the group will return to automatic operation.

Set a group/several groups in **Standby**

Press the function button.

>> The control menu will appear.

Select the groups to be stopped and press menu field "⏻ **STANDBY**".

>> The groups will stop in 1 hour (time can be adjusted to 0, 1, 2, ... 255 hours using a PC with Airlinq Service Tool loaded) and then start at the next start signal. Otherwise, the groups can be started earlier by using the "START" menu field. The air flow indicator will flash slowly alongside minimum.

Switch **off** a group/several groups

Press the function button.

>> The control menu will appear.

Select the groups to be switched off and press menu field "⏻ **OFF**".

Switch off system

Press the function button for min. 2 seconds, if the system or at least one group is running.

>> All units will switch off.

After switching off, the groups / the system must be started manually using the menu fields "AUTO" or "START".

4.3. Warning and Alarm



In the event of warnings and alarms, a triangle with an exclamation mark in its centre with a yellow or red light (pos. 4 under “Control Elements” on page 11) will show in the top left hand corner of the control panel main screen.

Press the symbol.

>> The control panel will show a large triangular warning/alarm text and “CALL SERVICE” for alarms, plus a telephone number.

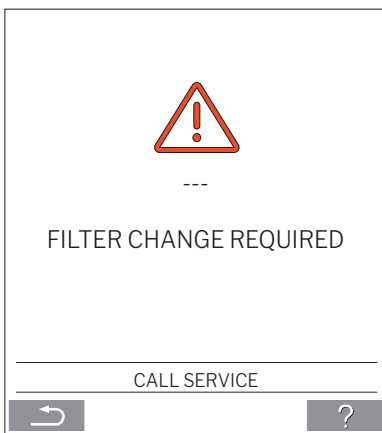

In the event of several warnings or alarms, they will be shown in order of priority.

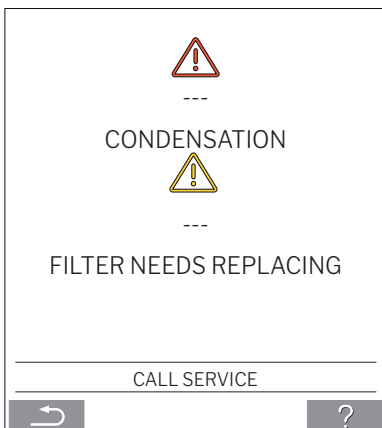

Display of warnings and alarms with the unit's ID number in an Airlinq BMS system. See page 21.

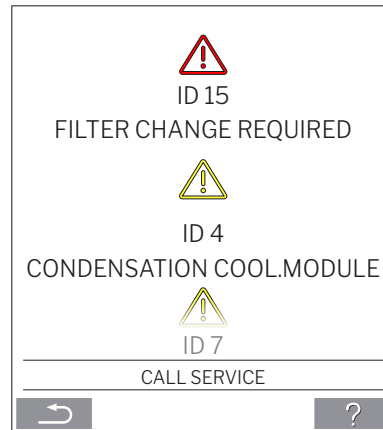

An ID number can be changed to another designation in Airlinq Service Tool.

Warnings (yellow):

The air handling unit remains in operation in the event of a warning, but operation can be limited. (See also the explanatory text under “Warning and Alarm” on page 9 and the key to abbreviations under “Abbreviations” on page 40.)

- Condensation Cool.module (in the cooling module).
- Compressor locked (stopped).
- Filter needs replacing.
- Group Master Missing. (Airlinq BMS only.) *1
- Technical fault (Temperature sensor (RT, OTV, OT, EVi, EVo or HG), flow measurement or CO₂ sensor. The cooling module will be out of action if faults on OT, EVi, EVo or HG occur.) *2

Alarms (red):

The air handling unit will stop to prevent damage in the event of an alarm. (See also the explanatory text under “Warning and Alarm” on page 9 and the key to abbreviations under “Abbreviations” on page 40.)

Low temperature.

- Condensation (in the air handling unit).
- Filter change required.
- Critical fault (Temperature sensor (IT, ETV), supply air fan or extract air fan.) *2

*1: See “Status - Installation Check” on page 16.

*2: See “Status - Hardware” on page 16.

5. Airmaster Airlinq® Online

Airlinq Online is a professional web portal for Airmaster air handling units connected to Ethernet. The portal is a cloud-based service, and the servers that handle communication with the systems are located in 'the cloud'. All communication is securely encrypted. Airlinq Online is designed to control, monitor and manage ventilation solutions for one or more installations.

The access to Airlinq Online is possible from a smart phone, a tablet, or a personal computer. There is no need to install any software or application. All you need is internet access through your internet browser.

Login

When activated your access to the service through the Airmaster Airlinq® Online invitation email go to <https://online.airlinq.eu> in your browser to login to Airlinq Online.

When you log onto Airlinq Online, you will always see an administration page first. The administration page provides a full overview of all of your air handling units.

The screenshot displays the Airlinq Online web portal interface. At the top, there is a navigation bar with 'AIRLINQ | ONLINE' on the left and 'Firmware', 'Devices', 'Groups', and 'Help' on the right. Below the navigation bar, the main content area is titled 'Device overview'. It includes a search bar, a filter dropdown set to 'Academy', and a summary of 'Devices in total: 5'. There are also status indicators for '3 OK', '2 Warnings', '0 Alarms', and '0 Disconnected'. The main table lists five air handling units with the following data:

Name	Airflow	Operation	Air quality	Temperature	Status
AM300 Path: -- AM300 AM 300 - S/N: 0000000	30%	Started by Timer System mode Auto	CO ₂ : 439 ppm TVOC: 149 ppb	Room: 20.7°C	Filterchange needed Low temp process
AM500+CC Path: -- AM500+CC AM 500 - S/N: 0000000	30%	Started by Timer System mode Auto	CO ₂ : 437 ppm TVOC: 128 ppb	Room: 21.3°C	Filterchange needed
AM900 Path: -- AM900 AM 900 - S/N: 0000000	30%	Started by Timer System mode Auto	CO ₂ : 437 ppm TVOC: 51 ppb	Room: 20.9°C	High temp process
Academy - Showroom Path: -- Academy - Showroom AMX 4 - S/N: 0000000	100%	Started by Timer System mode Comfort	CO ₂ : 609 ppm RH: 31 %	Room: 23.6°C	OK
Undervisningslokale Academy Path: -- Undervisningslokale Academy AM 1000 - S/N: 0000000	30%	Started by Timer System mode Auto	CO ₂ : 431 ppm TVOC: 114 ppb	Room: 20.4°C	OK

At the bottom of the table, there is a 'Per page:' dropdown set to '10' and a page indicator showing '1'.

The footer of the page contains the AIRMMASTER logo, contact information (+45) 9862 4822, info@airmaster.dk, Terms and Conditions, and social media icons for LinkedIn and Facebook.

6. LED signals

As the standard option, AMC 150, AM 150 and 300 are equipped with an LED in the input opening to show the operation status. The LED also shows warnings and alarms.

Individual signal types:

_ : LED is off (intervals of whole seconds).

I : LED is on (intervals of whole seconds).

Signals with priority 1 to 6:

Pri.	Signal	Off/on time	Meaning
1	_ _ _ _ _ _ _ _	off 1 s and on 1 s, 4 times; pause 5 s; repeat	Buzz alarm without filter alarm
2	_ _ _ _ _ _ _	off 1 s and on 1 s, 3 times; pause 5 s; repeat	Filter alarm
3	_ _ _ _ _ _	off 1 s and on 1 s, 2 times; pause 5 s; repeat	Buzz warning without filter warning
4	_ _ _ _ _ _	off 1 s and on 1 s; pause 5 s; repeat	Filter warning
5		light constantly on	Operation without warning or alarm (Option)
6	-----	LED off	Operation without warning or alarm ; No operation, warning or alarm

The highest active priority is shown within the programmed period of time (default: 07:00 to 22:00).

The signal for priority 5 ("Operation without warning or alarm") can be deactivated.

Buzz warning without filter warning (priority 3) includes the following warnings:

- Condensate in the cooling module
- Cooling module compressor locked (stopped). Module out of operation. Condenser overheated for an extended period.
- Technical error in the temperature sensors (RT, OTV, OT, EVi, EVo or HG) or CO₂ sensor. In case of errors OT, EVi, EVo or HG, the cooling module is out of order. Certain internal control system functions are working insufficiently if faults RT and OTV occur.

Call service.

Buzz alarm without filter alarm (priority 1) includes the following alarms:

- Low temperature alarm,
- Condensate in air handling unit,
- Technical fault in a temperature sensor (IT, ETV) or a fan.

Call service.

See also the explanatory text under "Warnings and alarms" on page 9 and the meanings of the abbreviations under "Abbreviations" on page 40.

7. Control functions

7.1. Timer-controlled ventilation

This function controls the Airmaster unit fully automatically according to a timer using an integrated clock.

Timer-controlled ventilation can be set using the control panel menu or Airlinq User Tool.

This function has 7 independent programs available. Day, start and stop times, air flow and inlet temperature can all be individually set for all programs.

7.2. Night time cooling

Night time cooling starts and stops the air handling unit using the integrated timer. The function starts the air handling unit even if it has not been in operation if the temperature parameters are fulfilled.

The night time cooling function is active as standard. Settings can be made using the control panel menu, Airlinq User Tool or Airlinq Service Tool. It can be used to reduce the room temperature (RT) during the night, if the temperature has exceeded the nominal values "NC High" (if night time cooling was not active the previous night), or "NC Low" (if night time cooling was active the previous night) in the daytime. It works with a parameter setting (high air flow and low inlet temperature) optimised to cool down the contents of the room and the building to limit room temperature during the day.

If the air handling unit has a cooling module and bypass damper, the inlet temperature (IT) can be regulated.

Standard settings:

The function is active	
Start time:	00:00
Stop time:	06:00
Air flow:	Boost
Inlet temperature:	14 °C
Temperature upper limit "NC High":	26 °C
Temperature lower limit "NC Low":	23 °C
Activation status:	active

7.3. Holiday mode

Holiday mode is used as basic ventilation when the room is unused for an extended period, e.g. holidays.

In holiday mode, Airlinq will run the unit with min. air flow.

The internal control function "Low Temperature" is active to protect the unit against ice formation. The control function is able to activate the heating surfaces if necessary.

The internal control function "High Temperature" is deactivated in holiday mode.

See Internal control functions "Low Temperature ("Low Temp")" on page 28 and "High Temperature ("High Temp")" on page 29.

7.4. Start and stop using external contacts

It can be necessary to start or stop the unit automatically using an external contact. See the Installation Manual.

The start and stop functions via external contact can also be used when the unit is running e.g. basic ventilation. This gives the user the option of switching the unit into another mode and back again.

External contacts:

- Switch
- Hygrostat
- etc.

7.4.1. Built-in smoke detector (optional)

If the unit has a built-in smoke detector the smoke detector functions as an external start/stop, hence the unit will stop if the smoke detector is activated. In this case, the smoke detector must be reset before the unit can start again.

Resetting the smoke detector is described in the smoke detector manual, see the Oppermann manual which is part of the delivery.

7.5. Start and stop using a PIR sensor

The air handling unit is set to start/stop via a signal from a PIR (motion) sensor. When a signal is received from the PIR sensor because of movement in the sensor's detection field, the unit will start at the standard air flow set (default flow) and inlet temperature (default temp). When the signal ceases, the unit will stop once a after-run time has elapsed (factory set to 30 min).

The factory set parameters can be changed, and the PIR sensor can be deactivated using Airlinq Service Tool.

7.6. Control using a CO₂ sensor or a CO₂/TVOC sensor

A CO₂ or CO₂/TVOC sensor is used to control the air handling unit independent of the strain on the room's indoor climate. You can choose whether to let (1) the air flow be controlled by the sensor, (2) the system's entire operation be controlled by the sensor.

1. Air flow control

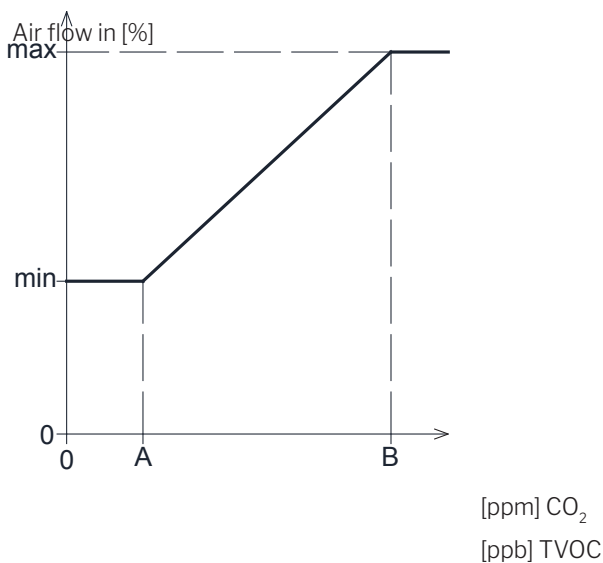

The unit can be set to run with a reduced basic air volume (min.) for basic ventilation.

If the CO₂/TVOC concentration in the room exceeds the programmed lower limit value (A), the sensor will take over and increase the air handling unit's air flow. If the CO₂/TVOC concentration in the room continues to rise, the air flow is linearly increased to the maximum air flow (max.) at the indoor climate level's upper limit value (B) and above.

For measurements between the lower and upper limit values, the air flow is fully automatically increased and reduced between the basic air flow and the maximum air flow.

If the CO₂/TVOC concentration returns to the programmed lower limit value (A) or below, the air handling unit will return to running on the basic air flow.

To use this function, the timer flow or the default flow has to be reduced. See "Timers" on page 17 or "Default Flow" on page 19.

2. Start, stop and air flow control

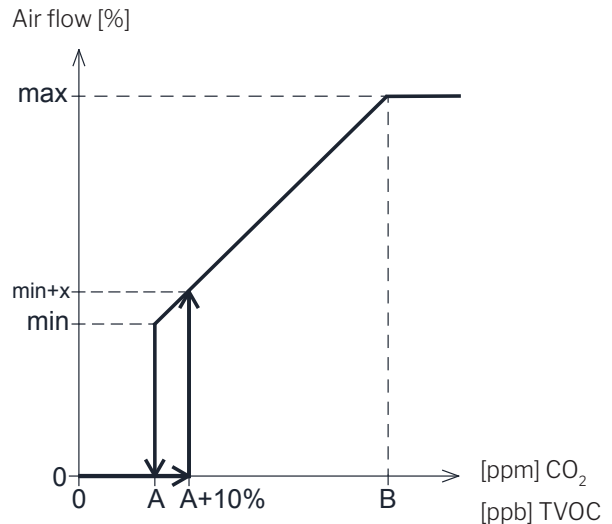

If the air handling unit is completely controlled by the sensor, it will start at slightly above the standard air flow (min. + x) when the CO₂/TVOC concentration exceeds the programmed lower limit value plus 10 % (A+10%).

If the CO₂/TVOC concentration in the room continues to rise, the air flow is linearly increased to the maximum air flow (max.) at the indoor climate level's upper limit value (B) and above.

For measurements between the lower and upper limit values, the air flow is fully automatically increased and reduced between the basic air flow and the maximum air flow.

If the CO₂/TVOC concentration falls below the programmed lower limit value (A), the air handling unit will stop.

To use this function, the CO₂ sensor or CO₂/TVOC sensor has to be programmed as a start parameter using the "Startup guide", Airlinq User Tool or Airlinq Service Tool.

Factory settings:

Lower limit A:	500 ppm (CO ₂ Min). 65 ppb (R_TVOCmin).
Upper limit B:	900 ppm (CO ₂ Max). 220 ppb (R_TVOCmax).
min:	30 % (Min air flow).
max:	100% (Max air flow).
Start Priority 7	CO ₂
Start Priority 8	TVOC

Settings can be made using the control panel menu points “Default Air Flow” (see page 19) and “Startup Guide” (see page 20), Airlinq User Tool or Airlinq Service Tool.

7.7. Boost

The boost function can adjust the airflow temporarily and is programmed to use some fixed control voltages for the supply air fan and the extract air fan respectively. It is possible to adjust the control voltages for the fans independently of each other if unbalanced ventilation is required.

The function is activated by an external switch that is connected to an input terminal at the main box.

The air handling unit stops the normal operation and activates the boost function when the contact closes. If the signal is disrupted, the unit will return to the previous operating mode (after-run time is factory set to 0 min). In case the air handling unit is stopped the boost function will start it.

7.8. Control using an analogue BMS

An air handling unit can be controlled using an A-BMS (analogue **B**uilding **M**anagement **S**ystem), which can start and stop the unit, and regulate air flow and inlet temperature.

The A-BMS can be fitted with an alarm signal (alarm contact) from the air handling unit, when the unit registers an internal alarm.

The A-BMS will start the unit using a start/stop signal and then control air flow and inlet temperature.

It is also possible to start and stop the unit using an A-BMS and then operate and set it using the control panel. See also “Installation Manual - External Connections”.

7.9. Cooling module operation

The cooling module reduces the supply air temperature before the air passes through the air handling unit.

The cooling module operates on demand, and is monitored by the Airlinq control system. In general, the cooling module will start if the room temperature is too high, or the inlet temperature exceeds its setpoint for high outside temperature.

When running, the cooling module adjusts air flow fully automatically according to demand. If the air flow is manually reduced to below the minimum necessary, there is a risk of damage to the cooling module. Consequently, the control system will stop the cooling module.

8. Internal control functions

Internal control functions run automatically, and influence air flow and inlet temperature. An internal control function is shown under control panel menu point “Status”, or using the Airlinq User Tool or Airlinq Service Tool.

8.1. Low temperature (“Low Temp”)

The “Low Temperature” internal control function protects the heat exchanger against ice forming at low outside temperatures, and maintains the inlet temperature (IT) when the temperature conditions are too low for the standard parameters. The control function increases the inlet temperature (IT) independently and/or protects the heat exchanger by reducing the supply air and increasing the extract air. It thus creates unbalanced ventilation. It runs regardless of whether the unit has heating surfaces or not.

If the unit is fitted with preheater and comfort heater, the control system can maintain balanced operation even at very low temperatures.

The control system function starts automatically when:

1. The inlet temperature (IT) falls 2 °C below the inlet temperature setpoint

or

2. If there is a risk of ice forming on the heat exchanger.

8.2. Preheat

The Preheat internal control function ensures unit operation at low outside temperatures, when the unit has an electric preheater surface. The control system switches on the heater automatically as required. The heating surface will heat up the cold supply air before it reaches the heat exchanger, preventing ice forming on the heat exchanger.

8.3. Virtual preheat

Virtual preheat ensures unit operation (along with the preheat process) at low outside temperatures for the AM 150 unit.

It can operate in two different modes: “Comfort mode” as standard and “Green mode” as an option.

Settings are made using a PC running the Airlinq Service Tool.

Comfort mode:

The bypass damper will be opened gradually to direct the supply air past the heat exchanger direct to the comfort heater, which will heat the air to inlet temperature (IT).

If the heater’s capacity is utilised to its maximum, the unit will start to operate as described in the internal control function “Low Temperature (“Low Temp”) on page 28.

Green mode:

This setting works in the opposite way to “Comfort mode”. The function begins by creating unbalanced ventilation and if this is insufficient, will regulate the bypass damper as described in “Comfort mode”.

8.4. High temperature (“High Temp”)

“High Temperature” automatically reduces the inlet temperature (IT) or the room temperature (RT) to a limited extent if necessary. The internal control function requires that the unit is fitted with a bypass damper.

Inlet temperature (IT):

The control function gradually opens the bypass damper if the inlet temperature (IT) rises 2 °C above the setpoint.

When the bypass damper opens, some of the air is directed past the heat exchanger. This reduces supply air heating.

Room temperature (RT):

High room temperature is preprogrammed at 25°C. At this temperature, the upper limit of the temperature range described as “comfort temperature” is exceeded.

When the room temperature (RT) exceeds the setpoint, the inlet temperature (IT) is reduced automatically.

This means that the room temperature (RT) can be limited to an acceptable level.

Setpoint is set using the control panel menu point “High Temperature” (see also page 19) or a PC running Airlinq User Tool or Airlinq Service Tool.

To ensure trouble-free operation, we recommend programming high room temperature higher than the normal room temperature.

The control function can regulate the inlet temperature (IT). Similarly, the control system can increase air flow to 100%, if the inlet temperature is at least 5°C under the room temperature.

The control function is active until the room temperature (RT) falls 1 °C under the programmed limit “High temperature”.

If the air handling unit is fitted with a cooling module, it will be triggered automatically when the bypass damper is fully open.

The bypass damper will still be used for regulating inlet temperature (IT).

The cooling module will stop again when the bypass damper has been closed for 5 minutes.

9. Service and maintenance

Service and maintenance are vital for problem-free operation of an Airmaster unit and its equipment. The majority of servicing consists of cleaning and inspection of the condensate system and filter change. We recommend that all service is performed by authorised experts.

Please contact your service partner by phone or mail to agree service provision.

9.1. External cleaning

The air handling unit must be switched off before cleaning.

To remove dirt from the control panel, sensors, cooling module and air handling unit, use a soft, damp cloth and clean water, or water with a mild detergent added (e.g. washing up liquid).

Do not use aggressive substances (e.g. turpentine) or sharp objects (such as a scraper) to clean the ventilation system components.

The extract air grille and air vents must be regularly cleaned. We recommend vacuum cleaning using a soft brush nozzle.

The space between the air handling unit and ceiling can be dusted using a feather duster. A soft brush vacuum nozzle can also be used if there is sufficient room.

9.2. Internal cleaning

Internal cleaning is recommended when changing filter. If dirt gets in to an Airmaster unit/cooling module, remove with a vacuum cleaner or soft brush.

The unit must be switched off and disconnected from the mains before the access covers on the unit and cooling module can be opened.

Check the cleanliness of components when performing internal cleaning. This applies in particular to the counter-flow heat exchanger and fans.

9.3. Cleaning the condensate system

The condensate system must be cleaned minimum annually and must be controlled at every filter change.

Condensate pump:

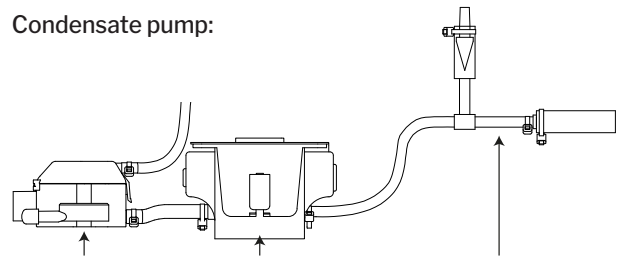

Float housing Condensate pump Drain hose

The condensate pump is fitted as standard on the cooling module, and is an optional extra for the air handling unit.

AM1200: The condensate pump is behind a service access cover under the extract air panel.

- Remove the condensate tray (cooling modules only).
- Remove the float housing and supply hose.
- Open the float housing cover.
- Clean all individual parts.
- Replace all the above in reverse order.

All condensate hoses in the condensate system must be secured again with a suitable hose clip.

- Pour approx. a half litre water into the condensate tray, switch on the power briefly and check that the water is pumped out and that there are no leaks.

Condensate tray:

A condensate tray is fitted as standard to all air handling units and cooling modules.

The plug, drain house and tray can all be easily removed for cleaning the drain and hose. We recommend cleaning the drain and hose when changing filter.

9.4. Filter change

All filters in the air handling unit (incl. cooling module) are monitored by the unit's filter monitoring system. Replace the filters whenever the monitoring system indicates that a filter must be changed, but at least every 14 months.

Be aware of any specific, deviating local rules.

Filter monitoring can be adapted to local conditions using Airlinq Service Tool. The filters are tested automatically daily (time can be set using "Airlinq Service Tool").



NB! Used filters must be disposed of according to their contamination with particles (waste code 1502), atmospheric particles (waste code 150203) or 'hazardous' substances (waste code 150202).



NB! When changing the filter, we recommend using appropriate safety equipment such as safety goggles, disposable gloves and a dust mask. Used filters must immediately be disposed of in a dustproof bag after they have been removed from the unit.

The control system filter monitoring must be reset after a filter change.

9.4.1. Reset service (filter change)

Airlinq Viva:

Reset filter change alarm by pressing and holding the holiday mode button and function button simultaneously for 10 seconds. The unit will then automatically start, the control panel will flash a short amber warning symbol followed by a short red alarm symbol.

Airlinq Orbit:

Reset the filter alarm under control panel menu "Settings - Reset Service" or using a PC running Airlinq Service Tool.

>> Press "Confirm" to reset service or "Cancel" to cancel the reset.

>> Enter the code (Standard "9732") and confirm. See sect. "Lock Screen" on page 20.

Units with no control panel:

The filter change alarm must be reset using a PC running Airlinq User Tool, Airlinq Service Tool or Airlinq Online.

9.4.2. Cooling module filter change

NB! When changing filters, the unit must be switched off (press function button for at least 2 seconds), disconnected from the mains and prevented from being switched on.



- Carefully open the service cover while it is supported.

NB! Open the side of the wall frame first. The service cover is heavy.



- Slacken the retaining plate (certain models only) and pull out the old filter on the fresh air side of the frame. (1)
- Clean the inside of the cooling module and supply air duct, check component condition and cleanliness. Clean the components if necessary.
- Insert a new filter with the correct direction of flow in the filter frame. The arrow on the side of new filters shows flow direction. The arrow must point into the unit. Fit the retaining plate (certain models only).

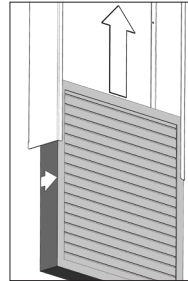

- Close the service cover in reverse order, lock covers.
- Replace the extract air filter (2) on the air handling unit. See sect. "Filter Change for AM 150, 300, 500, 800, 1000, AMC 150" on page 32.

Filter position:

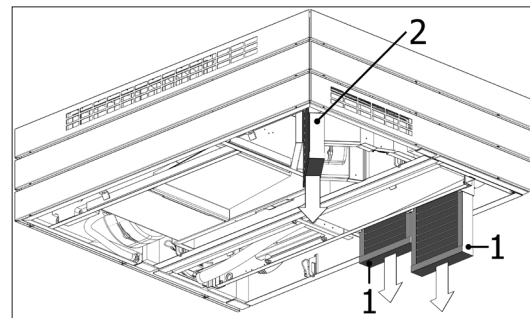

or

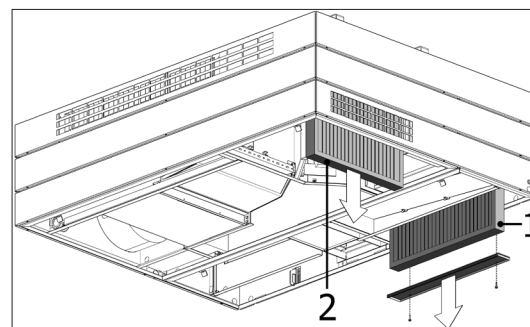

9.4.3. Filter change for AM 150, 300, 500, 800, 1000, AMC 150

These units are fitted with an extract air filter and one or two supply air filters unless fitted with a cooling module, in which case the air handling unit will only have one extract air filter.

NB! When changing filters, the unit must be switched off (press function button for at least 2 seconds), disconnected from the mains and prevented from being switched on.



- Carefully open the service cover while it is supported.

NB! Open the side of the wall frame first. The service cover is heavy (AM 500 and 800 only).



- Slacken the service cover(s) (certain models only) and pull the old filters out of their frames.
- Clean the inside of the unit and supply air duct, check component condition and cleanliness. Clean the components if necessary.
- Insert new filters with the correct direction of flow in the filter frames. The arrow on the side of new filters shows flow direction. The arrow must point into the unit. Fit the retaining plate(s) (certain models only).

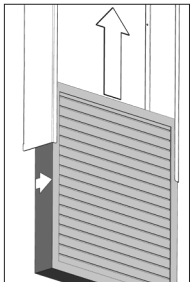

- Close the service cover in reverse order, lock covers.
- Reconnect to the mains and start the unit.
- Reset service. See “Reset Service” on page 31.

Filter position:

AMC 150, AM 150, 300, 500, 800 H: Supply air filter (1) and extract air filter (2) without retaining plate.

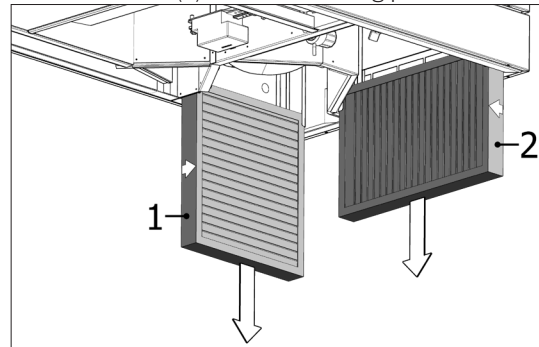

AM 500V: Two supply air filters (1) visible behind a retaining plate, extract air filter (2) without retaining plate.

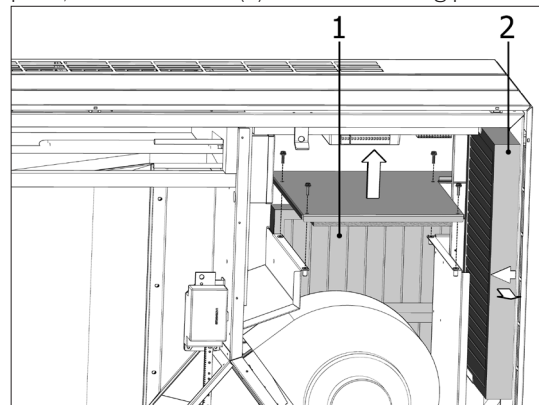

AM 800V: Two supply air filters (1) visible behind a retaining plate under one extract air filter (2) with retaining plate.

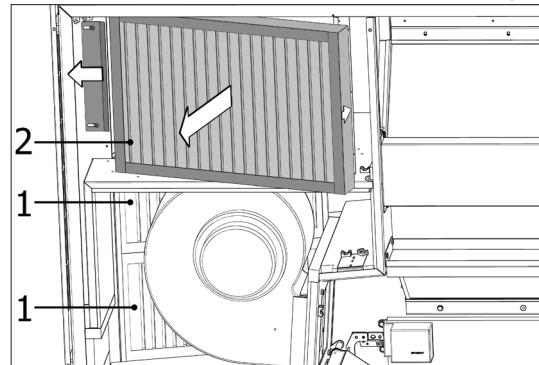

Retaining plate for supply air filters (1) under extract air filter.

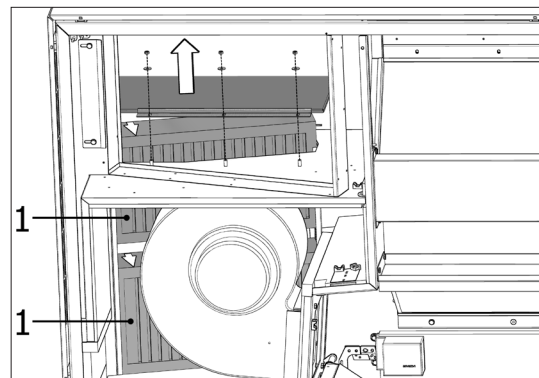

AM 1000: Supply air filter (1) under a cover (3) and extract air filter (2).

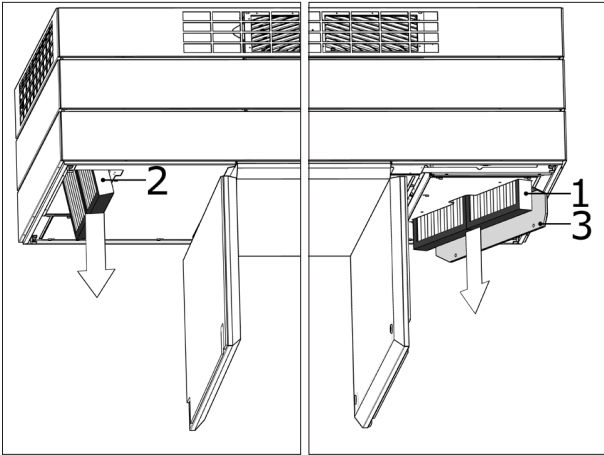

9.4.4. Filter change AM 900 and AM 1200

NB! When changing filters, the unit must be switched off (press function button for at least 2 seconds), disconnected from the mains and prevented from being switched on.



- Open the unit front cover (AM 900) / remove side panels and extract panel (AM 1200).
- Remove the filter retaining plate and pull the old filters out of their frames.
- Clean the inside of the unit and supply air duct, check component condition and cleanliness as far as possible. Clean the components if necessary.
- Insert new filters with the correct direction of flow in the filter frames. (The arrow on the side of new filters shows flow direction. The arrow must point into the unit).

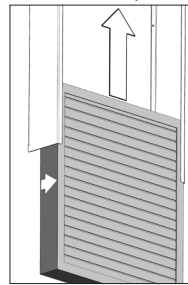

- Fit the retaining panels and service cover/panels.
- Close the front cover (AM 900) / mount side panels and extract panel (AM 1200).
- Reconnect to the mains and start the unit.
- Reset service. See “Reset Service” on page 31.

Filter position AM 900:

Supply air filter (1) behind the service cover on top of a AM 900 unit.

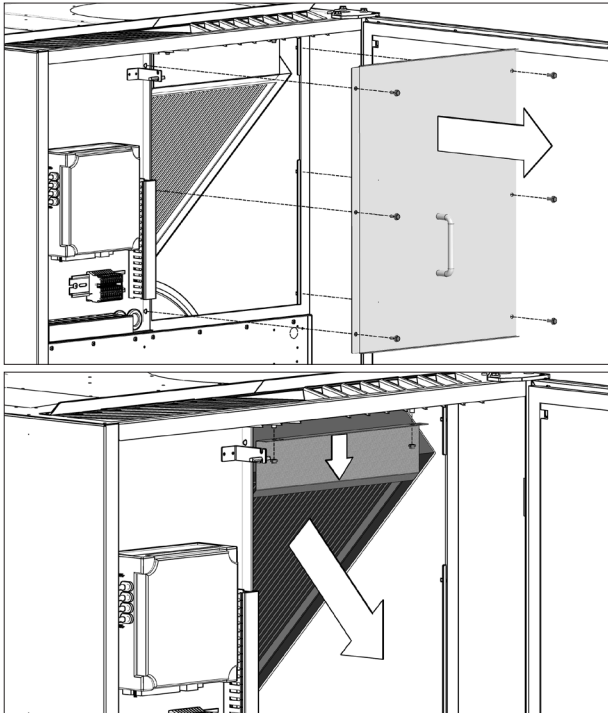

Extract air filter (2) at the bottom of the front cover.

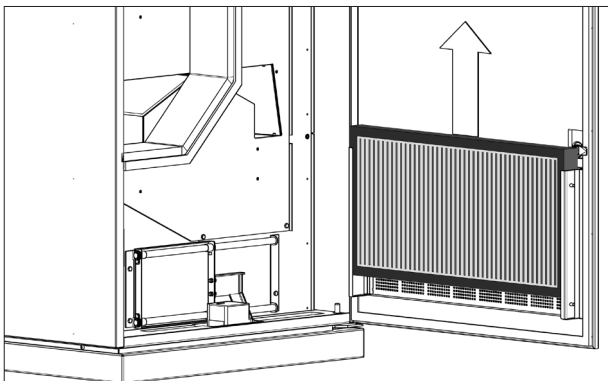

Filter position AM 1200:

Supply air filter is fitted behind the side panels on the motor section and is accessible from the left and right sides. Extract air filter is fitted behind the extract panel.

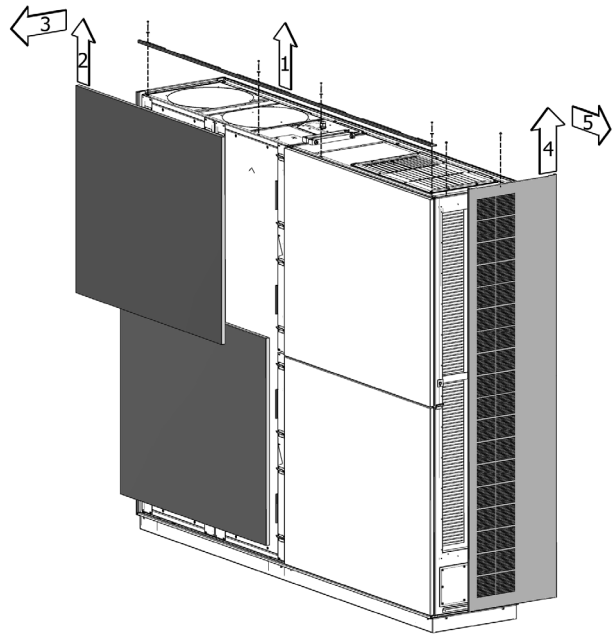

Supply air filter (1) is fitted under a service cover and extract air filters (2) are fitted using a retaining plate.

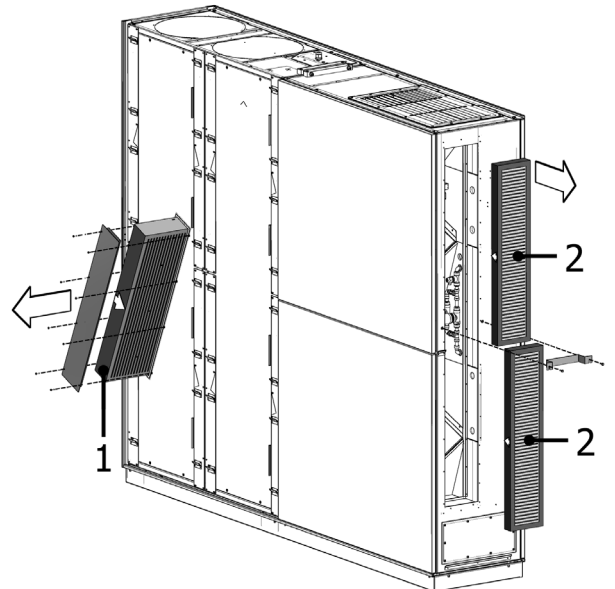

9.5. Filter list

Standard filters supply air path + extract air path: Glas fiber filters ePM₁₀ 50% + ePM₁₀ 50%:

Unit	Supply air path [mm]	Extract air path [mm]	Part number
AM 150	195 x 185 x 92	195 x 185 x 92	922069
AM 150 + CC 150 (cooling module)	195 x 185 x 92	195 x 185 x 92	922069
AM 300	280 x 220 x 47	280 x 220 x 47	923031
AM 500 Horizontal	380 x 340 x 47	470 x 300 x 47	923032
AM 500 Vertical	190 x 340 x 47 (2 pcs)	470 x 300 x 47	923033
AM 500 + CC 500 (cooling module)	560 x 284 x 47	470 x 300 x 47	923067
AM 800 Horizontal	420 x 408 x 92	325 x 480 x 47	923034
AM 800 Vertical	408 x 216 x 92 (2 pcs)	325 x 480 x 47	923035
AM 800 + CC 800 (cooling module)	560 x 284 x 47	325 x 480 x 47	923068
AM 900	360 x 480 x 92	710 x 350 x 47	920901
AM 1000 (not S1S2)	650 x 480 x 47	650 x 480 x 47	930578
AM 1000 S1S2	325 x 480 x 47 (2 pcs)	650 x 480 x 47	930575
AM 1200	790 x 404 x 92	820 x 174 x 47 (2 pcs)	923057

Optional filters supply air path + extract air path: Glas fiber filters ePM₁ 55% + ePM₁₀ 50%:

Unit	Supply air path [mm]	Extract air path [mm]	Part number
AM 150	195 x 185 x 92	195 x 185 x 92	
AM 150 + CC 150 (cooling module)	195 x 185 x 92	195 x 185 x 92	
AM 300	280 x 220 x 47	280 x 220 x 47	
AM 500 Horizontal	380 x 340 x 47	470 x 300 x 47	
AM 500 Vertical	190 x 340 x 47 (2 pcs)	470 x 300 x 47	
AM 500 + CC 500 (cooling module)	560 x 284 x 47	470 x 300 x 47	
AM 800 Horizontal	420 x 408 x 92	325 x 480 x 47	
AM 800 Vertical	408 x 216 x 92 (2 pcs)	325 x 480 x 47	
AM 800 + CC 800 (cooling module)	560 x 284 x 47	325 x 480 x 47	
AM 900	360 x 480 x 92	710 x 350 x 47	
AM 1000 (not S1S2)	650 x 480 x 47	650 x 480 x 47	
AM 1000 S1S2	325 x 480 x 47 (2 pcs)	650 x 480 x 47	
AM 1200	404 x 790 x 92	820 x 174 x 47 (2 pcs)	

Optional filters intake air path + extract air path: glas fiber filters ePM₁ 80% + ePM₁₀ 50% upon request.

9.6. Smoke detector (optional built-in)

Please refer to the Oppermann manual for service and maintenance. The manual is part of the delivery.

The smoke detector is located in the front section of the unit, to access it please follow the instructions below. You only need to open one service cover to access the smoke detector.

Inlet top:

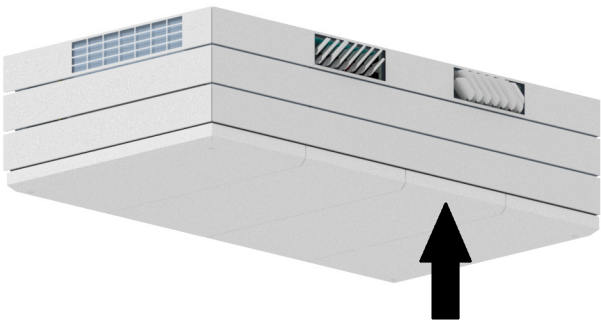

Inlet bottom (built-in):

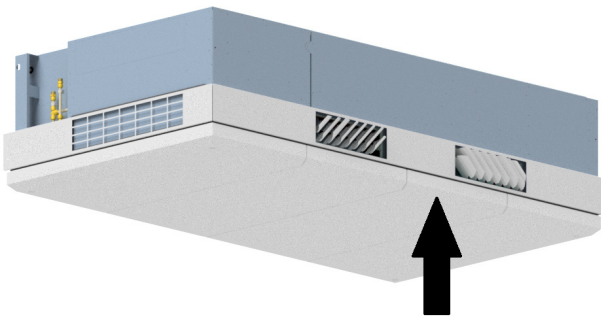

Ducted inlet:

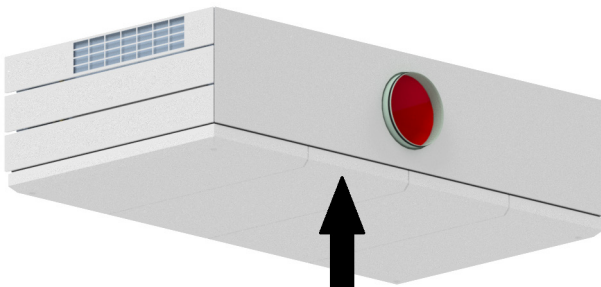

9.7. Setting inlet air grille

AM 150

The size of the inlet opening of AM 150 is adaptable to the throw length and inlet air pattern (see 'Datasheet AM 150').

The inlet air grille louvres can be bent slightly using longnosed pliers to adjust inlet direction. See the section 'Setting slats on the AM 150, 300, 500 and 800' and 'Datasheet AM 150'.

AM 300

The size of the inlet opening of AM 300 is adaptable to the throw length and inlet air pattern (see 'Datasheet AM 300').

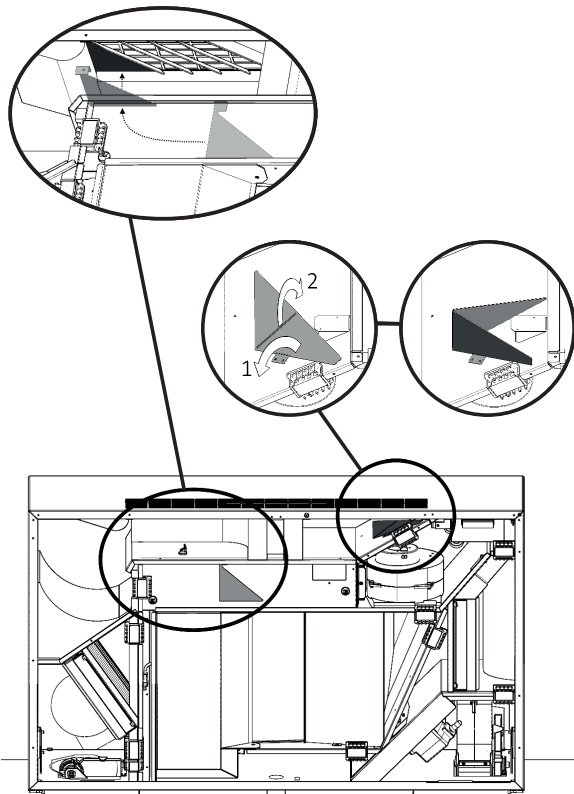

The inlet air grille louvres can be bent slightly using longnosed pliers to adjust inlet direction. See the section 'Setting slats on the AM 150, 300, 500 and 800' and 'Datasheet AM 300'

Setting slats on the AM 150, 300, 500 and 800

The inlet air grille louvres can be bent slightly using longnosed pliers to adjust inlet direction.

NB! It is only possible to bend the slats a few times, otherwise they can break off.

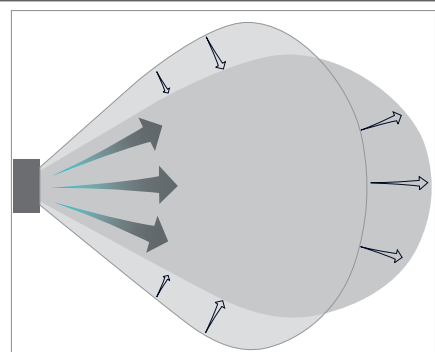
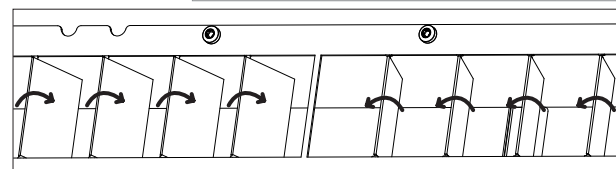
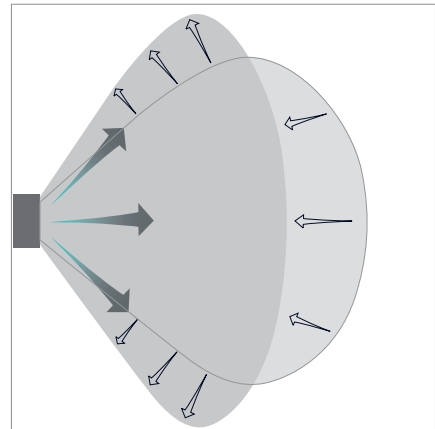
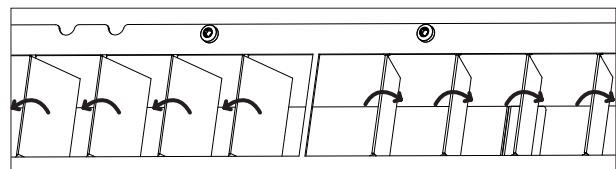
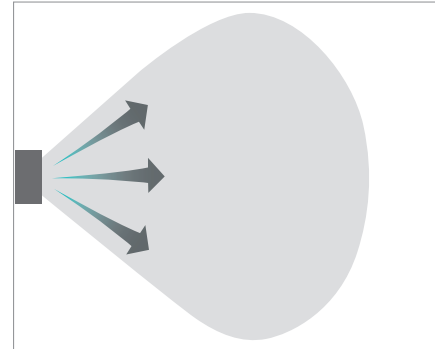
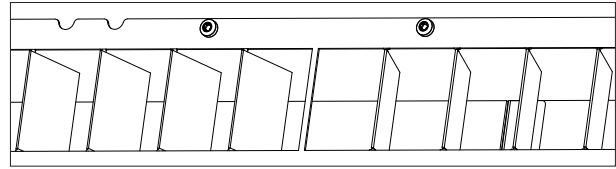

AM 1000 and RC 1000

Only with manual adjustment!

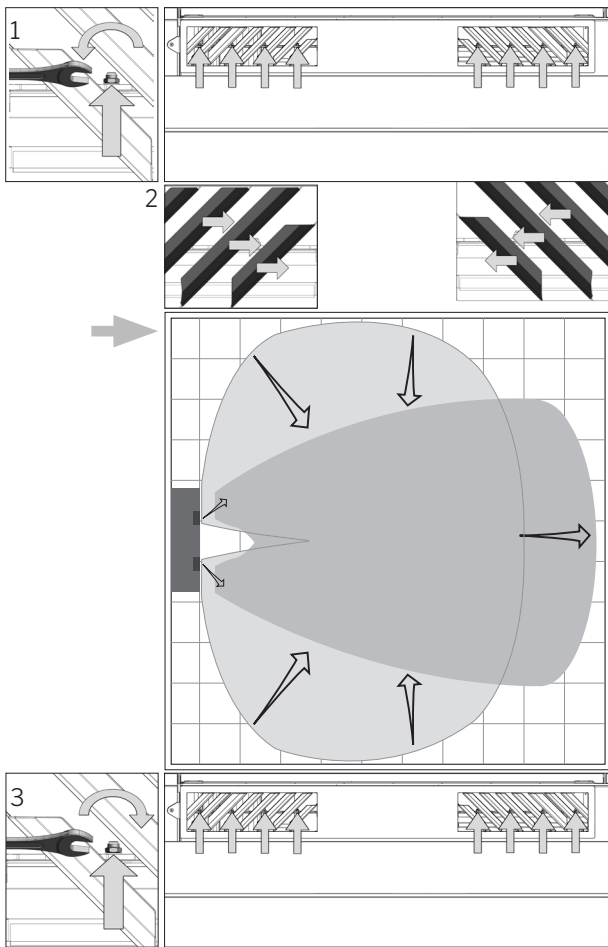

AM 1200

The inlet air grille louvers can be bent slightly using longnosed pliers to adjust inlet direction.

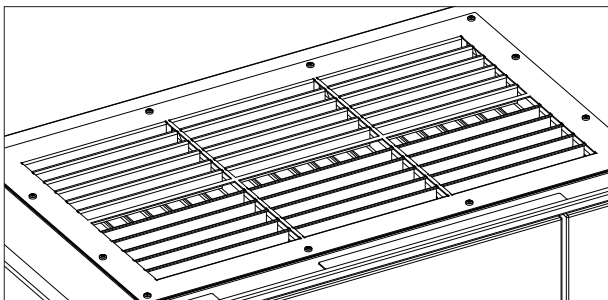

AM 900

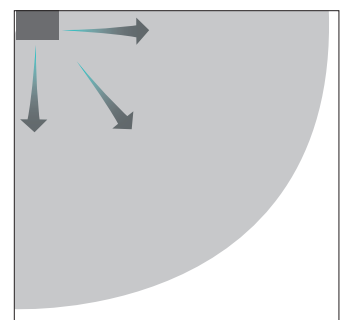
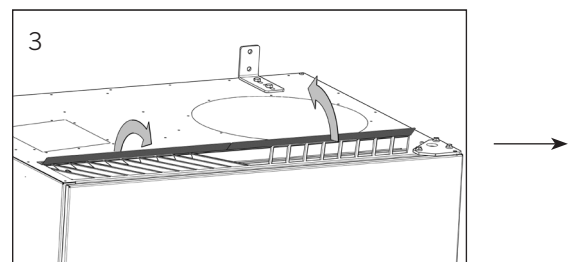
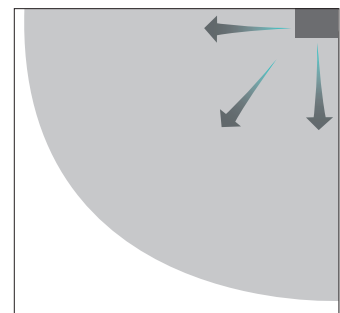
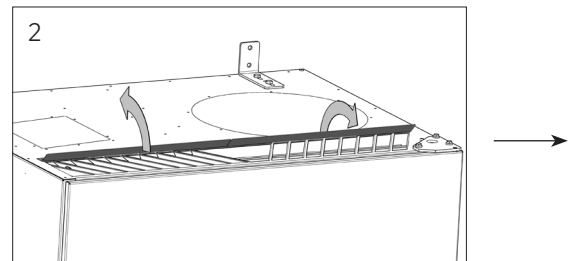
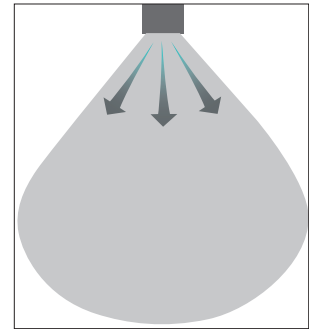
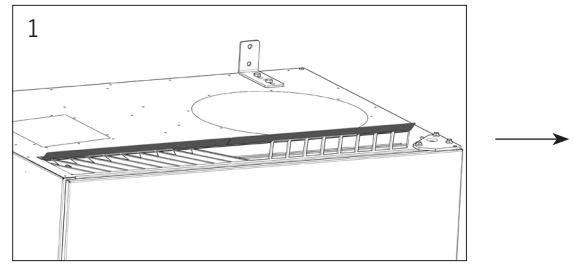

9.8. Safety Instructions Cooling Modules

Cooling modules are exempt from the directive for pressure equipment (PED) according to article 1, part 3.6.

Maintenance and Repair

Maintenance can be performed by the end user, but repairs of cooling modules must be performed by authorised experts.

Transport/Storage

Cooling modules can only be transported/stored standing on its service cover. The unit may, however, be tipped up to 80 degrees for up to 60 seconds.

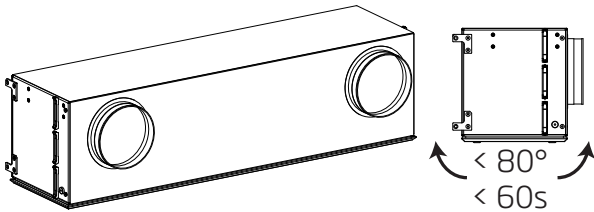

10. Repairs and Improvements

All repairs and improvements must be performed by authorised experts.

The AQC-L control box contains a varistor that protects against overvoltage. In the case of a defective control box, this glass fuse can be checked. If the glass fuse is faulty, it must be changed.

Please contact your service partner by phone or mail to agree service provision.

11. Dismounting

Should the unit need to be dismantled, follow the installation in reverse.



N.B. The power must be turned off before dismantling.

1. The ventilation unit is dismantled.
2. Electricity connection is disconnected.
3. The internal part is dismantled.
4. The outside part is dismantled.
5. The hole in the wall is closed.

12. Disassembly

Product information according to "Commission Regulation (EU) No 1253/2014, annex IV – Information requirements for RVUs as referred to in Article 4(1)" and product information according to "Commission Regulation (EU) No 1254/2014, annex IV – Product finche as referred to in Article 3(1)(a)" can be found on our website.

Direct link: [Declarations](#), choose 'Disassembly'.

It contains a description of the required tools and procedures for manual disassembly for the effective recycling of materials.

13. Disposal

N.B. Disposal must be performed by authorised experts according to actual rules and by-laws.



The cooling module must e.g. be drained of coolant and oil according to actual rules and by-laws before disposal.

Air handling units and cooling modules contains among other things electric and electronic equipment that must be disposed and recycled according to actual rules and by-laws. The unit must not be disposed of as domestic waste.

14. Error Description

Control panel blank

1. Unit switched off.
Start unit manually. See page 7 or 13.
2. No electricity supply.
Switch on mains electricity.
3. Control panel or data cable defective.
CALL SERVICE.

Unit cannot be operated:

1. Control panel automatic operating, child or screen lock active.
Deactivate lock. See page 6, 11 or 20.

Control panel air indicator flashing:

2. Data connection from control panel to unit broken
CALL SERVICE.

Unit blowing too cold:

1. Inlet temperature set too low.
Check setting. See page 18 and 19.
2. Room heater set too low.

Draught from unit, room feels cold:

1. Inlet temperature set too low.
Check setting. See page 18 and 19.
2. Air flow too low. Increase air flow.
3. Room heater set too low.
4. The inlet opening louvres are not set correctly. See page 36.

Abbreviations

%	Percent	RC 1000	Cooling module for AM 1000
°C	Degrees Celsius	RPM	Revolutions Per Minute
A	Analogue	RT	Room Temperature
AI	Analogue input	Temp.	Temperature
AM	Airmaster Air Handling Unit	TVOC	Total Volatile Organic Compounds
AQC L	Airlinq Controller, type L, black box	USB	Universal Serial Bus
AQC P	Airlinq Controller, type P, grey box		
BMS	Building Management System		
CC	Cooling module		
CdT	Condenser temperature		
CO ₂	Carbon dioxide		
D	Digital		
EMC	Electromagnetic compatibility		
ePM ₁₀ 70%	Filter class (ISO 16890)		
ePM ₁₀ 75%	Filter class (ISO 16890)		
ePM _{2,5} 65%	Filter class (ISO 16890)		
ePM ₁ 55%	Filter class (ISO 16890)		
ePM ₁ 80%	Filter class (ISO 16890)		
ePM ₁ 85%	Filter class (ISO 16890)		
EPP	Expanded Polypropylene		
ET	Exhaust Temperature (Cooling Module)		
ETV	Exhaust Temperature Air Handling Unit		
EV _i	Evaporator temperature in		
EV _o	Evaporator temperature out		
EvT	Evaporator temperature		
G	Group		
HG	Hot Gas		
ID	Identification		
IT	Inlet Temperature		
IT (set)	Setpoint Inlet Temperature		
m ³ /h	Cubic metres per hour		
Max	Maximum		
Min	Minimum		
NC High	Night time cooling temperature upper limit		
NC Low	Night time cooling temperature lower limit		
OT	Outside Temperature (cooling module)		
OTV	Outside Temperature Air Handling Unit		
PIR	Passive Infrared Sensor		
ppm	Parts per million		

Product Information According to DIRECTIVE 2009/125/EC

Product information according to "Commission Regulation (EU) No 1253/2014, annex IV - Information requirements for RVUs as referred to in Article 4(1)" and "Commission Delegated Regulation (EU) No 1254/2014, Annex IV - Product fiche".

a)	Supplier	Airmaster		
b)	Model	AM 150	AM 300	
c)	Specific energy consumption (SEC)			
	Cold climate	-79,1 kWh/(m ² · a)	-78,6 kWh/(m ² · a)	
	Average climate	-41,5 kWh/(m ² · a)	-40,8 kWh/(m ² · a)	
	Warm climate	-17,4 kWh/(m ² · a)	-16,6 kWh/(m ² · a)	
	SEC class	A	A	
d)	Typology	Residential ventilation unit / Bidirectional ventilation unit		
e)	Type of drive installed	Variable speed drive (VSD)		
f)	Type of heat recovery system	Recuperative heat exchanger / Counterflow heat exchanger		
g)	Thermal efficiency	82 %	83 %	
h)	Maximum flow rate	0,035 m ³ /s @ 20 Pa	0,075 m ³ /s @ 30 Pa	
		126 m ³ /h @ 20 Pa	270 m ³ /h @ 30 Pa	
i)	Electric power input	30 W	95 W	
j)	Sound power level (L _{WA})	40 dB(A)	40 dB(A)	
k)	Reference flow rate	0,025 m ³ /s	0,057 m ³ /s	
		89 m ³ /h	205 m ³ /h	
l)	Reference pressure difference	20 Pa	20 Pa	
m)	Specific power input (SPI)	730 W/(m ³ /s)	950 W/(m ³ /s)	
		0,203 W/(m ³ /h)	0,264 W/(m ³ /h)	
n)	Control factor and typology	MISC = 1,21	MISC = 1,21	
		Non-ducted unit		
		CTRL = 0,65	CTRL = 0,65	
		Local demand control		
		X = 2	X = 2	
	Variable speed drive (VSD)			
o)	Maximum external leakage rate	2 % @ 250 Pa	2 % @ 250 Pa	
		Maximum internal leakage rate	2 % @ 100 Pa	
p)	Mixing rate	Max. 5 % at unfavourable wind direction and speed		
q)	Filter alarm signal	See description in Operation & Maintenance Manual		
r)	Instructions regarding unidirectional ventilation unit	Not relevant		
s)	Disposal	See description in Operation & Maintenance Manual, www.airmaster-as.com/en/		
t)	Airflow sensitivity to pressure variations	+/- 7,9 %	+/- 3,7 %	
u)	Air tightness	1,5 m ³ /h	1,5 m ³ /h	
v)	Annual electricity consumption (AEC)			
		Cold climate	687 kWh/(100 m ² ·a)	736 kWh/(100 m ² ·a)
		Average climate	150 kWh/(100 m ² ·a)	199 kWh/(100 m ² ·a)
		Warm climate	105 kWh/(100 m ² ·a)	154 kWh/(100 m ² ·a)
w)	Annual heating saved (AHS)			
		Cold climate	8785 kWh/(100 m ² ·a)	8829 kWh/(100 m ² ·a)
		Average climate	4490 kWh/(100 m ² ·a)	4513 kWh/(100 m ² ·a)
		Warm climate	2031 kWh/(100 m ² ·a)	2041 kWh/(100 m ² ·a)

Product information according to “Commission Regulation (EU) No 1253/2014, Annex V - Information requirements for NRVUs as referred to in Article 4(2)”.

a)	Manufacturer	Airmaster		
b)	Model	AM 500	AM 800	AM 900
c)	Typology	Non-residential ventilation unit / Bidirectional ventilation unit		
d)	Type of drive installed	Variable speed drive (VSD)		
e)	Type of heat recovery system	Recuperative heat exchanger / Counterflow heat exchanger		
f)	Thermal efficiency	82 %	84 %	89 %
g)	Nominal flow rate	0,110 m ³ /s 396 m ³ /h	0,167 m ³ /s 600 m ³ /h	0,185 m ³ /s 665 m ³ /h
h)	Electric power input	0,12 kW	0,11 kW	0,15 kW
i)	Internal specific fan power (SFP _{int})	1011 W/(m ³ /s) 0,281 W/(m ³ /h)	664 W/(m ³ /s) 0,184 W/(m ³ /h)	670 W/(m ³ /s) 0,186 W/(m ³ /h)
j)	Face velocity	0,8 m/s	1,0 m/s	1,0 m/s
k)	Nominal external pressure ($\Delta p_{s,ext}$)	20 Pa	20 Pa	20 Pa
l)	Internal pressure drop of ventilation components ($\Delta p_{s,int}$)	195 Pa	111 Pa	114 Pa
m)	Internal pressure drop of non-ventilation components ($\Delta p_{s,add}$)	Water Comfort Heater: 10 Pa	Water Comfort Heater: 10 Pa	Water Comfort Heater: 10 Pa
n)	Static efficiency of fans	40 %	39 %	37 %
o)	Maximum external leakage rate Maximum internal leakage rate	2 % @ 400 Pa 2 % @ 250 Pa	2 % @ 400 Pa 2 % @ 250 Pa	2 % @ 400 Pa 2 % @ 250 Pa
p)	Energy performance of the filters	206 kWh/a, Class A+	330 kWh/a, Class A+	459 kWh/a, Class A+
q)	Filter alarm signal	See description in Operation & Maintenance Manual		
r)	Sound power level (L _{WA})	40 dB(A)	40 dB(A)	40 dB(A)
s)	Disposal	See description in Operation & Maintenance Manual, www.airmaster-as.com		
	Specific requirements 2018			
	Thermal efficiency	>73%	>73%	>73%
	Internal specific fan power (SFP _{int,limit})	1354 W/(m ³ /s)	1406 W/(m ³ /s)	1552 W/(m ³ /s)

a)	Manufacturer	Airmaster	
b)	Model	AM 1000	AM 1200
c)	Typology	Non-residential ventilation unit / Bidirectional ventilation unit	
d)	Type of drive installed	Variable speed drive (VSD)	
e)	Type of heat recovery system	Recuperative heat exchanger / Counterflow heat exchanger	
f)	Thermal efficiency	80 %	84 %
g)	Nominal flow rate	0,264 m ³ /s 950 m ³ /h	0,264 m ³ /s 950 m ³ /h
h)	Electric power input	0,23 kW	0,17 kW
i)	Internal specific fan power (SFP _{int})	771 W/(m ³ /s) 0,214 W/(m ³ /h)	491 W/(m ³ /s) 0,136 W/(m ³ /h)
j)	Face velocity	0,8 m/s	0,8 m/s
k)	Nominal external pressure ($\Delta p_{s,ext}$)	20 Pa	20 Pa
l)	Internal pressure drop of ventilation components ($\Delta p_{s,int}$)	194 Pa	85 Pa
m)	Internal pressure drop of non-ventilation components ($\Delta p_{s,add}$)	Water Comfort Heater: 10 Pa	Water Comfort Heater: 10 Pa
n)	Static efficiency of fans	55 %	38 %
o)	Maximum external leakage rate Maximum internal leakage rate	2 % @ 400 Pa 2 % @ 250 Pa	2 % @ 400 Pa 2 % @ 250 Pa
p)	Energy performance of the filters	261 kWh/a, Class A+	450 kWh/a, Class A+
q)	Filter alarm signal	See description in Operation & Maintenance Manual	
r)	Sound power level (L _{WA})	40 dB(A)	40 dB(A)
s)	Disposal	See description in Operation & Maintenance Manual, www.airmaster-as.com	
	Specific requirements 2018		
	Thermal efficiency	>73%	>73%
	Internal specific fan power (SFP _{int,limit})	1270 W/(m ³ /s)	1390 W/(m ³ /s)

Product information according to "COMMISSION REGULATION (EU) No 206/2012, ANNEX I, 3. PRODUCT INFORMATION REQUIREMENTS, table 2 - Information requirements".

Description	Symbol	Unit	CC150	CC 500
Rated capacity for cooling	P_{rated} for cooling	[kW]	0,7	3,3
Rated capacity for heating	P_{rated} for heating	[kW]	Not relevant	Not relevant
Rated power input for cooling	P_{EER}	[kW]	0,1	1,0
Rated power input for heating	P_{COP}	[kW]	Not relevant	Not relevant
Rated Energy efficiency ratio	EER_d	[-]	4,3	3,2
Rated Coefficient of performance	COP_d	[-]	Not relevant	Not relevant
Power consumption in thermostat-off mode	P_{TO}	[W]	0	0
Power consumption in standby mode	P_{SB}	[W]	0	0
Electricity consumption of double duct appliances	Q_{DD}	[kWh/a]	50	364
Sound power level	L_{WA}	[dB(A)]	<30	44
Global warming potential	GWP	[kg CO2 eq.]	1430	2088
Contact details for obtaining more information			Airmaster A/S, Industrivej 59, DK-9600 Aars	

Description	Symbol	Unit	CC 800	CC1000
Rated capacity for cooling	P_{rated} for cooling	[kW]	5,2	6,5
Rated capacity for heating	P_{rated} for heating	[kW]	Not relevant	Not relevant
Rated power input for cooling	P_{EER}	[kW]	1,1	1,5
Rated power input for heating	P_{COP}	[kW]	Not relevant	Not relevant
Rated Energy efficiency ratio	EER_d	[-]	4,7	4,5
Rated Coefficient of performance	COP_d	[-]	Not relevant	Not relevant
Power consumption in thermostat-off mode	P_{TO}	[W]	0	0
Power consumption in standby mode	P_{SB}	[W]	0	0
Electricity consumption of double duct appliances	Q_{DD}	[kWh/a]	389	508
Sound power level	L_{WA}	[dB(A)]	45	54
Global warming potential	GWP	[kg CO2 eq.]	2088	2088
Contact details for obtaining more information			Airmaster A/S, Industrivej 59, DK-9600 Aars	

EU Declaration of Conformity

Manufacturer Airmaster A/S
Industrivej 59
DK-9600 Aars
Denmark

Herewith declare that the following air handling unit (series and type (serial numbers))

Product AM 50 (0500001-0501720)
AM 150 (3404252-3499999)
AM 300 (3000006-3099999)
AM 500 (0314234-0399999)
AM 800 (0908896-0999999)
AM 900 (0501721-0599999)
AM 950 C (8100001-8199999)
AM 950 F (8200001-8299999)
AM 1000 (1002448-1099999)
AM 1200 (0800422-0899999)
AM 150 (3404252-3499999) with CC 150 (3600426-3699999)
AM 500 (0314234-0399999) with CC 500 (1300768-1399999)
AM 800 (0908896-0999999) with CC 800 (1400864-1499999)

is in conformity with provisions of the following EC directives:

Directives Directive 2006/42/EC of the European Parliament and of the Council of 17 May 2006 of machinery.

Directive 2014/30/EC of the European Parliament and of the Council of 26 February 2014 on the harmonisation of the laws of the Member States relating to electromagnetic compatibility.

Directive 2009/125/EC of the European Parliament and of the Council of 21 October 2009 establishing a framework for the setting of ecodesign requirements for energy-related products.

Directive 2011/65/EU of the European Parliament and of the Council of 8 June 2011 on the restriction of the use of certain hazardous substances in electrical and electronic equipment.

Reservation This declaration is not valid if modifications are made to the product without approval by Airmaster A/S.

Place Aars

Date 2025-04-30

Signature 
Jesper Mogensen
CTO

This page is intentionally left blank

This page is intentionally left blank

AIRMASTER